

DEPARTMENT OF TRANSPORT**NOTICE 883 OF 2022****MERCHANT SHIPPING ACT, 1951(ACT NO. 57 OF 1951)****DRAFT MERCHANT SHIPPING (CONSTRUCTION AND EQUIPMENT OF FISHING VESSELS OF 24 METRES IN LENGTH AND OVER.) REGULATIONS, 2022**

The Minister of Transport hereby in terms of section 356 of the Merchant Shipping Act, 1951 (Act No. 57 of 1951), publishes for comments the draft Merchant Shipping (Construction and Equipment of Fishing Vessels of 24 metres in Length and over) Regulations, 2022 as indicated in the Schedule.

Interested persons are invited to submit written comments on this draft Regulations 2022, within 30 days from the date of publication of this notice in the Government Gazette.

All comments should be posted or emailed to the Director-General Department of Transport for attention of Ms Glory Semenya at:

Department of Transport
Private Bag x 193
Pretoria
0001

E-mail: semenyag@dot.gov.za or matlalatm@dot.gov.za

Tel: 012 309 3499 or 012 309 3799

SCHEDULE

Regulation No.

CHAPTER I

GENERAL PROVISIONS

1. Definitions
2. Application
3. Objects of the regulations
4. Exemptions
5. Equivalentents
6. Repairs, Alterations and Modifications
7. Surveys
8. Issue and Format of Safety Certificates
9. Display of Safety Certificates
10. Duration of Safety Certificates
11. Cancellation of Safety Certificates
12. Designated Person Ashore
13. On Board Safety Officers

CHAPTER II

SURVEYS

14. General
15. Hull

16. Tanks
17. Shafts and Rudders
18. Sea Connections
19. Anchors, Cables, Wires and Steering Chains
20. Steering Gear and Emergency Arrangements
21. Boilers which permit a full Internal Examination
22. Boilers which do not permit a full Internal Examination
23. Steam Pipes
24. Main and Auxiliary Machinery
25. Air Receivers and Pressure Vessel
26. Refrigeration Systems used for the Preservation of Catch
27. Electrical Equipment

CHAPTER III

CONSTRUCTION, WATERTIGHT INTEGRITY AND EQUIPMENT

28. Submission and Approval of Plans
29. Inspections, Tests and Surveys of New Constructions
30. Construction and Structural Strength
31. Bulkheads and Double Bottoms
32. Watertight Doors
33. Watertight Integrity
34. Weathertight Doors
35. Hatchways Closed by Wood Covers
36. Factories

37. Machinery Space Openings
38. Other Deck Openings
39. Testing of Watertight and Weathertight Compartments
40. Ventilators
41. Air Pipes
42. Sounding Pipes and Devices
43. Side Scuttles and Windows
44. Inlets and Discharges
45. Freeing Ports
46. Anchoring Equipment
47. Mooring Equipment

List of Annex's

- | | | |
|-------|-----|--|
| Annex | 1 - | Vessel Construction: Plans and Particulars |
| Annex | 2 - | Anchoring, Mooring and Towing Equipment |

CHAPTER IV

STABILITY AND ASSOCIATED SEAWORTHINESS

48. Provision of Stability Information
49. Form of Stability Information
50. General Intact Stability Criteria
51. Loading Conditions
52. Lightship
53. Dry Docking Condition

54. Anti-Rolling/Stabilisation Devices
55. Severe Wind and Rolling
56. Icing Considerations
57. Lifting of Weights
58. Fixed Ballast
59. Form of the Righting Arm (GZ) Curve
60. Subdivision and Damaged Stability
61. Water on Deck
62. Flooding of Fish Holds
63. Portable Fish Hold Divisions
64. Bow Height
65. Maximum Permissible Operating Draught
66. Additional/Alternative Criteria
67. Sister Ships
68. Special Cases
69. Reliability of Information

List of Annex's

- | | | |
|--------------|-----|---|
| Annex | 3 - | Information to be provided in Stability Books |
| Annex | 4 - | General Precautions against Capsizing for Ships |
| Annex | 5 - | Severe Wind and Rolling Criterion (Weather Criterion) |
| Annex | 6 - | Icing Considerations |
| Annex | 7 - | Lifting of Heavy Weights Over the Side |
| Annex | 8 - | Minimum Freeboard and Bow Height |
| Annex | 9 - | Flow Chart for the Reliability of Stability Information |

CHAPTER V

MACHINERY AND ELECTRICAL INSTALLATIONS AND PERIODICALLY UNATTENDED MACHINERY SPACES

PART A - GENERAL

- 70. Machinery Installations
- 71. Electrical Installations
- 72. Periodically Unattended Machinery Spaces

PART B- MACHINERY INSTALLATIONS

- 73. Main and Auxiliary Machinery
- 74. Main Engine Starting Arrangements
- 75. Means of Going Astern
- 76. Steam Boilers, Feed Systems and Steam Piping Arrangements
- 77. Communication between Wheelhouse and Machinery Space
- 78. Wheelhouse Control of Propulsion Machinery
- 79. Air Pressure Systems
- 80. Arrangements for Fuel Oil, Lubricating Oil and other Flammable Oils
- 81. Bilge Pumping Arrangements
- 82. Steering Gear
- 83. Engineers' Alarm
- 84. Refrigeration Systems for Preservation of Catch
- 85. Ventilation

PART C- ELECTRICAL INSTALLATIONS

- 86. Main Source of Electrical Power
- 87. Emergency Source of Electrical Power
- 88. Precautions against Shock, Fire and other Hazards of Electrical Origin

PART D- PERIODICALLY UNATTENDED MACHINERY SPACES

89. Fire Safety
90. Protection against Flooding
91. Communications
92. Alarm Systems
93. Special Requirements for Machinery, Boiler and Electrical Installations
94. Safety System

CHAPTER VI**FIRE PROTECTION, FIRE DETECTION, FIRE EXTINCTION AND****FIRE FIGHTING****PART A - FIRE SAFETY MEASURES FOR VESSELS
LESS THAN 60 METRES IN LENGTH**

95. Structural Fire Protection
96. Ventilation Systems
97. Heating Installations
98. Remote Fuel Stops
99. Miscellaneous Items
100. Storage of Gas Cylinders and Dangerous Materials
101. Means of Escape
102. Automatic Alarm and Fire Detection Systems
103. Fire Pumps
104. Fire Mains
105. Fire Hydrants, Fire Hoses and Nozzles
106. Fire Extinguishers

107. Portable Fire Extinguishers and Fire Blankets in Control Stations and Accommodation and Service Spaces
108. Fire Extinguishing Appliances in Machinery Spaces
109. Fireman's Outfits
110. Availability of Fire Appliances
111. Equivalent, Approval of Types and Servicing of Fire Appliances
112. Use of Halon

**PART B - FIRE SAFETY MEASURES FOR VESSELS OF
60 METRES IN LENGTH AND OVER**

113. General
114. Structure
115. Bulkheads within the Accommodation and Service Spaces
116. Protection of Stairways and Lift Trunks in Accommodation Spaces, Service Spaces and Control Stations
117. Doors in Fire-Resistant Divisions
118. Fire Integrity of Bulkheads and Decks
119. Details of Construction
120. Ventilation Systems

121. Remote Fuel Stops
122. Miscellaneous Items
123. Storage of Gas Cylinders and Dangerous Materials
124. Means of Escape
125. Automatic Sprinkler and Fire Alarm and Fire Detection Systems (Method IIF)

- 126. Automatic Fire Alarm and Fire Detection Systems (Method IIIF)

- 127. Fixed Fire-Extinguishing Arrangements in Cargo spaces of High Fire Risk
- 128. Fire Pumps
- 129. Fire Mains
- 130. Fire Hydrants, Fire Hoses and Nozzles

- 131. Fire Extinguishers
- 132. Portable Fire Extinguishers and Fire Blankets in Control Stations and Accommodation and Service Spaces
- 133. Fire Extinguishing Appliances in Machinery Spaces
- 134. International Shore Connection
- 135. Fireman's Outfit
- 136. Fireman's Control Plan
- 137. Availability of Fire Appliances
- 138. Equivalentents, Approval of Types and Servicing of Fire Appliances
- 139. Use of Halon

CHAPTER VII

PROTECTION OF THE CREW

- 140. General Protection Measures
- 141. Safe Access
- 142. Deck Openings
- 143. Bulwarks, Rails and Guards

144. Stairways and Ladders
145. Lifting Appliances, Pulleys and Wire Ropes
146. Safeguarding of Machinery
147. Protection against Noise
148. Use of Asbestos
149. Standard Operating Procedures

List of Annex's

Annex 1 - Maximum Recommended Noise Levels

CHAPTER VIII

CREW ENVIRONMENT

150. Position of Crew Accommodation
151. Height of Crew Accommodation
152. Bulkheads and Paneling
153. Overhead Decks
154. Flooring
155. Protection from Weather
156. Heating
157. Lighting
158. Ventilation
159. Drainage
160. Painting, etc.
161. Sleeping Rooms
162. Bunks
163. Furniture and Fittings
164. Mess Rooms

- 165. Furniture and Fittings in Mess Rooms
- 166. Recreation Rooms
- 167. Sanitary Facilities
- 168. Supply of Drinking Water
- 169. Laundry Facilities
- 170. Galleys
- 171. Dry Provision Store Rooms
- 172. Cold Store Rooms and Refrigerating Equipment
- 173. Hospitals
- 174. Medical Cabinet
- 175. General
- 176. Maintenance and Inspection of Crew Accommodation
- 177. Inspection by the Authority

List of Annex's

Annex 1 - Trunked Mechanical Ventilation Systems

CHAPTER IX
SHIPBORNE NAVIGATIONAL EQUIPMENT AND
ARRANGEMENTS

- 178. Compasses

- 179. Depth Sounding Equipment
- 180. Global Positioning Systems
- 181. Vessel Manoeuvring Data
- 182. Radar
- 183. Speed and Distance Indicator
- 184. Nautical and Other Publications and Documentation
- 185. Signaling Equipment
- 186. Navigating Bridge Visibility

CHAPTER X

LIFE SAVING APPLIANCES AND ARRANGEMENTS

PART A - GENERAL

- 187. Evaluation, Testing and Approval of Radio Life Saving Appliances and Arrangements

PART B - VESSEL REQUIREMENTS

- 188. Number and Types of Survival Craft and Rescue Boats
- 189. Availability and Stowage of Survival Crafts and Rescue Boats
- 190. Embarkation into Survival Craft
- 191. Life Jackets
- 192. Immersions Suits and Thermal Protective Aids
- 193. Lifebuoys
- 194. Line Throwing Appliances
- 195. Distress Signals
- 196. Retro-reflective Materials on Life Saving Appliances
- 197. Operational Readiness, Maintenance and Inspections
- 198. Servicing of Life-saving Appliances

CHAPTER XI

EMERGENCY PROCEDURES, MUSTERS AND DRILLS

- 199. Muster Lists and Abandon Ship Procedures
- 100. Practice Musters and Drills

- 101. On Board Training

CHAPTER I

GENERAL PROVISIONS

1. Definitions

In these regulations, any expression to which a meaning has been assigned in the Act bears the meaning so assigned, unless the context indicates otherwise:

“**Act**” means the Merchant Shipping Act, 1951 (Act 57 of 1951);

“**AIS**” means Automatic Information System;

“**angle of down flooding**” means the angle of heel at which openings which cannot rapidly be closed weathertight commence to immerse excluding small openings through which progressive flooding cannot take place need not be considered;

“**accommodation spaces**” means those spaces used for public spaces, such as,

corridors, lavatories, cabins, offices, hospitals, cinemas, games and hobbies rooms, pantries containing no cooking appliances and similar spaces;

“amidships” means the mid-length of the Length (L);

“approved” means approved by the Authority;

“approved Inspection Authorities” means:

(1) Any organisation that has been accredited by the chief inspector in terms of:

(a) SABS 0227 Part 1 to perform the functions regarding the certification of new vessels under pressure, inspections and testing; or

(b) SABS 0227 Part 2 to perform the functions regarding the certification of modified or repaired vessels under pressure, inspections and testing, as an approved inspection authority.

(2) Application for approval for an organisation as contemplated in subregulation (1) must be accompanied by a valid certificate issued by the South African Bureau of Standards in terms of SABS 0227 Part 1 and Part 2.

(3) The chief inspector may at any time withdraw any approval of an approved inspection authority, subject to the provisions of section 35 of the Act;

“auxiliary means of activating the rudder” is the equipment which is provided for effecting movement of the rudder for the purpose of steering the vessel in the event of failure of the main steering gear;

“baseline” means the horizontal line intersecting at amidships the keel line;

“boiler” means any apparatus to convert continuously, any liquid into steam, vapour or gas at a pressure higher than that due to the atmosphere and where the heat is derived

from a source other than steam or the ambient temperature of the atmosphere, and includes any superheater or economiser which is an integral part of a boiler or is separately fired therefrom, but does not include such an apparatus, superheater or economiser in which the product of the design pressure in pascal and the volume in cubic metres is less than the figure 15 000;

“**breadth (B)**” means the maximum moulded breadth of the vessel, measured amidships to the moulded line of the frame in a vessel with a metal shell and to the outer surface of the hull in a vessel with a shell of any other material;

“**Collision bulkhead**” mean a watertight bulkhead up to the working deck in the forepart of the vessel which meets the following conditions:

- (1) The bulkhead shall be located at a distance from the forward perpendicular:
 - (a) not less than $0.05L$ and not more than $0.08L$ for vessels of 45 metres in length and over;
 - (b) not less than $0.05L$ and not more than $0.05L$ plus 1.35 metres for vessels of less than 45 metres in length; or
 - (c) in no case less than 2.0 metres;
- (2) Where any part of the underwater body extends forward of the forward perpendicular, e.g. bulbous bow, the distance stipulated in sub-paragraph (a) shall be measured from a point at mid-length of the extension forward of the forward perpendicular or from a point $0.015L$ forward of the forward perpendicular, whichever is less;
- (3) The bulkhead may have steps or recesses provided they are within the limits prescribed in sub-paragraph (a);

“**control stations**” means those spaces in which the vessel’s radio or main

navigation equipment or the emergency source of power is located, or where the fire recording or fire control equipment is centralized;

“**crew**” means the skipper and all persons employed or engaged in any capacity on board a vessel on the business of that vessel;

“**critical period**” in relation to a ship which is being dry docked, is the time between the stern part (or fore part in exceptional circumstances) landing on the blocks and the ship taking the blocks overall;

“**dead ship condition**” means the condition under which the main propulsion plant, boilers and auxiliaries are not in operation due to the absence of power;

“**deepest operating waterline**” means the waterline related to the maximum permissible operating draught;

“**Depth (D)**” means the vertical distance measured amidships from the keel line to the top of the upper deck beam at side,

in vessels having rounded gunwales, the moulded depth shall be measured to the point of intersection of the moulded lines of the deck and side shell plating, the lines extending as though the gunwale were of angular design

where the working deck is stepped and the raised part of the deck extends over the point at which the moulded depth is to be determined, the depth shall be measured to a line of reference extending from the lower part of the deck along a line parallel with the raised part;

“**Displacement**” in relation to a ship, is the amount of water displaced by the ship’s hull at a given instant. In accordance with Archimedes Principle, the mass of a vessel equals the mass of water it displaces;

“draught” means the vertical distance from the underside of the keel, at a defined longitudinal position, to the waterline;

“enclosed superstructure” means a superstructure with enclosing bulkheads of efficient construction, access openings, if any, in those bulkheads fitted with permanently attached weathertight doors of a strength equivalent to the unpierced structure which can be operated from each side; and other openings in sides or ends of the superstructure fitted with efficient weathertight means of closing;

A bridge or poop shall not be regarded as enclosed unless access is provided for the crew to reach machinery and other working spaces inside those superstructures by alternative means which are available at all times when bulkhead openings are closed;

“enclosed volume” means the volume of the spaces in a vessel which can be closed watertight and weathertight and are used for determining the cross curves of stability;

“existing vessel” is a fishing vessel which is not a new vessel;

“factory” means a space where the cleaning and processing of fish is undertaken;

“Fishing vessel” or “vessel” means any vessel, boat, ship or other craft which is used for, equipped to be used for or of a type that is normally used for fishing or related activities, and includes all gear, equipment, stores, cargo and fuel on board the vessel;

“Float-free survival craft” are craft whose installations and stowage are intended to permit them to clear a sinking vessel and float to the surface automatically;

“Forward and after perpendiculars” shall be taken at the forward and after ends of the length (L). The forward perpendicular shall be coincident with the foreside of the stem on the waterline on which the length is measured;

“Free-fall launching” is that method of launching a survival craft whereby the craft and its complement of persons and equipment on board is released and allowed to fall into the sea without any restraining apparatus;

“Fuel oil unit” is the equipment used for the preparation of fuel oil for delivery to an oil-fired boiler, or equipment used for the preparation of oil for delivery to an internal combustion engine, and includes any oil pressure pumps, filters and heaters dealing with oil at a pressure greater than 0.18 newtons per square millimetre;

“GT” for a ship means, its Gross Tonnage calculated in terms of the *“Tonnage Regulations, 1968”*;

“Height of a superstructure or other erection” is the least vertical distance measured at side from the top of the deck beams of a superstructure or an erection to the top of the working deck beams;

“Inflatable appliance” is an appliance which depends upon non-rigid gas-filled chambers for buoyancy and is normally kept uninflated until ready for use.

“Inflated appliance” is an appliance which depends upon non-rigid gas-filled chambers for buoyancy and is kept inflated and ready for use at all times.

“keel line” is the line parallel to the slope of keel passing amidships through:

- (a) the top of the keel or line of intersection of the inside of shell plating with the keel where a bar keel extends above that line of a vessel with a metal shell;
- (b) the rabbet lower line of the keel of a vessel with a shell of wood or a composite vessel; or,
- (c) the intersection of a fair extension of the outside of the shell contour at the bottom with the centreline of a vessel with a shell of material other than wood and metal;

“launching appliance” is a device capable of launching, from the embarkation position, a craft fully loaded with the number of persons it is permitted to carry and with its equipment;

“length (L)” shall be taken as 96 per cent of the total length on a waterline at 85 per cent of the least moulded depth measured from the keel line, or as the length from the foreside of the stem to the axis of the rudder stock on that waterline, if that be greater. In vessels designed with rake of keel the waterline on which this length is measured shall be parallel to the designed waterline;

“Lifting Appliance” means any fixed or mobile appliance on a vessel which is used for suspending, raising or lowering a load or moving it from one position to another whilst suspended.

“Lightship condition” means the ship ready for sea, complete with permanent ballast, outfit and spare gear, machinery and systems, but with no fuel, fresh water, feed water, ballast water, lubrication oil, provisions, consumable stores, crew and effects or cargo on board;

“Linehauler recovery station” An area used for the recovery of the linehauler line and catch;

“Low flame spread” means that the surface thus described will adequately restrict the spread of flame, this being determined to the satisfaction of the Authority by an established test procedure;

“Machinery spaces of category A” are those spaces which contain internal combustion type machinery used either for:

- (a) main propulsion;
- (b) other purposes where such machinery has in the aggregate a total power output of not less than 750 kilowatts; or
- (c) which contain any oil-fired boiler or fuel oil unit;

“Machinery spaces” are those machinery spaces of category A and all other spaces containing propulsion machinery, boilers, fuel oil units, steam and internal combustion engines, generators, steering gear, major electrical machinery, oil filling stations, refrigerating, stabilizing, ventilating and air conditioning machinery and similar spaces, and trunks to such spaces;

“Main steering gear” is the machinery, the steering gear power units, if any, and ancillary equipment and the means of applying torque to the rudder stock (e.g. tiller or quadrant) necessary for effecting movement of the rudder for the purpose of steering the vessel under normal service conditions;

“Main switchboard” is a switchboard directly supplied by the main source of electrical power and intended to distribute electrical energy;

Master” means, in relation to a fishing vessel, any person (other than a pilot) having charge or command of such fishing vessel;

“Maximum astern speed” is the speed which it is estimated the vessel can attain at the designed maximum astern power at its maximum permissible operating draught;

“Maximum ahead service speed” is the greatest speed which the vessel is designed to maintain in service at sea at its maximum permissible operating draught;

“Midship section” is that section of the hull defined by the intersection of the moulded surface of the hull with a vertical plane perpendicular to the waterline and centreline planes passing through amidships;

“Mean draught” means the vertical distance from the underside of the keel amidships to the waterline;

“New vessel” is a fishing vessel for which on or after the date of entry into force of these Regulations:

- (a) the building or major conversion contract is placed;
- (b) the building or major conversion contract has been placed before the date of entry into force of the Regulations, and which is delivered three years or more after the date of such entry into force; or
- (c) in the absence of a building contract:
 - (i) the keel is laid;
 - (ii) construction identifiable with a specific vessel begins; or
 - (iii) assembly has commenced comprising at least 50 tonnes or 1 percent of the estimated mass of all structural material; whichever is the less;

“Non-combustible material” means a material which neither burns nor gives off flammable vapours in sufficient quantity for self-ignition when heated to approximately 750 degrees Celsius, this being determined to the satisfaction of the Authority by an established test procedure. Any other material is a combustible material;

“Normal operational and habitable conditions” means conditions under which the vessel as a whole, its machinery services, means of main and auxiliary propulsion, steering gear and associated equipment, aids to safe navigation and to limit the risks of fire and flooding, internal and external means of communicating and signalling, means of escape and winches for rescue boats, are in proper working order and the minimum comfortable conditions of habitability are satisfactory;

“Novel life-saving appliance or arrangement” is a life-saving appliance or arrangement which embodies new features not fully covered by the provisions of these Regulations but which provides an equal or higher standard of safety;

“Periodically unattended machinery spaces” means those spaces containing main propulsion and associated machinery and all sources of main electrical supply which are not at all times manned under all operating conditions, including manoeuvring;

“pressure vessel” means any vessel of which the interior or jacket is under pressure or in which a cushion of gas or vapour can form above the liquid at a pressure in excess of that of the atmosphere, but does not include –

- (a) a boiler;
- (b) a vessel in which the pressure is exerted by a liquid the temperature of which does not exceed the boiling point of the liquid at atmospheric pressure and in which a cushion of gas or vapour cannot form above the

liquid;

- (c) the working cylinders or chambers of a steam, heat or air engine;
- (d) a vessel under pressure which forms an integral operating part of a motor vehicle or locomotive running on railway lines;
- (e) a portable gas container;
- (f) a pressurised system;
- (g) a vessel of which the product of the design pressure in pascal and the capacity in cubic metres is less than the figure 15 000;
- (h) a vessel of which the design pressure is less than 40 000 pascal gauge pressure;
- (i) a vessel with a nominal internal diameter of less than 150mm; or
- (j) a hand-held fire extinguisher;

“pressurised system” means an assembly of vessels under pressure and includes connections by pipes or similar ducts, fittings and valves which operate under gauge pressure equal to or greater than 40 000 pascal for the process and conveyance of a flammable liquid, hazardous chemical substance, saturated steam or superheated steam;

“Public Spaces” are those portions of the accommodation spaces used for halls, dining rooms, lounges and similar permanently enclosed spaces.

“Steering gear power unit” means in the case of:

- (a) electric steering gear, an electric motor and its associated electrical equipment;
- (b) electro-hydraulic steering gear, an electric motor and its associated electrical equipment and connected pump; and
- (c) other hydraulic steering gear, a driving engine and connected pump;

“Superstructure” is the decked structure on the working deck extending from side to

side of the vessel or with the side plating not being inboard of the shell plating more than 0.04B;

“Superstructure deck” is that complete or partial deck forming the top of a superstructure, deckhouse or other erection situated at a height of not less than 1.8 metres above the working deck. Where this height is less than 1.8 metres, the top of such deckhouses or other erections shall be treated in the same ways as the working deck;

“Public spaces” are those portions of the accommodation spaces which are used for halls, dining rooms, lounges, and similar permanently enclosed spaces;

“Rescue boat” is a boat designed to rescue persons in distress and to marshall survival craft;

“Retro-reflective material” is a material which deflects in the opposite direction a beam of light directed on it;

“Service spaces” are those spaces used for galleys, pantries containing cooking appliances, lockers and store-rooms, workshops other than those forming part of the machinery spaces, and similar spaces and trunks to such spaces;

“Skipper” in relation to a fishing vessel shall have the same meaning as Master;

“Standard fire test” is one in which specimens of the relevant bulkheads or decks are exposed in a test furnace to temperatures corresponding approximately to the standard time-temperature curve. The specimen shall have an exposed surface of not less than 4.65 square metres and a height (or length of deck) of 2.44 metres, resembling as closely as possible the intended construction and including where

appropriate at least one joint. The standard time-temperature curve is defined by a smooth curve drawn through the following temperature points measured above the initial furnace temperature at the end of the first :

- (a) 5 minutes 556 degrees celsius;
- (b) 10 minutes 659 degrees celsius;
- (c) 15 minutes 718 degrees celsius;
- (d) 30 minutes 821 degrees celsius; and
- (e) 60 minutes 925 degrees celsius;

“Steel or other equivalent material” means steel or any material which, by itself or due to insulation provided, has structural and integrity properties equivalent to steel at the end of the applicable fire exposure to the standard fire test (e.g. aluminium alloy with appropriate insulation);

“Survival craft” is a craft capable of sustaining the lives of persons in distress from the time of abandoning the vessel;

“Tonne” 1 tonne = 1000 kg;

“Tons” means gross register tons (GT);

“Watertight” means capable of preventing the passage of water through the structure in any direction under a head of water for which the surrounding structure is designed;

“Weathertight” means that in any sea conditions water will not penetrate into the vessel;

“Working deck” is generally the lowest complete deck above the deepest operating waterline from which fishing is undertaken. In vessels fitted with two or more complete

decks, the Authority may accept a lower deck as a working deck provided that that deck is situated above the deepest operating waterline;

“vessels under pressure” means a vessel which operates under pressure and includes a boiler, pressure vessel, pressurised system or portable gas container;

“A class divisions” are those divisions formed by bulkheads and decks which comply with the following:

- (a) they shall be constructed of steel or other equivalent material.
- (b) they shall be suitably stiffened;
- (c) they shall be so constructed as to be capable of preventing the passage of smoke and flame to the end of the one-hour standard fire test; and
- (d) they shall be insulated with approved non-combustible materials such that the average temperature of the unexpected side will not rise more than 139 degrees celsius above the original temperature, nor will the temperature, at any one point, including any joint, rise more than 180 degrees celsius above the original temperature, within the time listed below:
 - (i) Class “A-60” 60 minutes
 - (ii) Class “A-30” 30 minutes
 - (iii) Class “A-15” 15 minutes
 - (iv) Class “A-0” 0 minutes

The Authority may require a test of a prototype bulkhead or deck to ensure that it meets the above requirements for integrity and temperature rise;

“B class divisions” are those divisions formed by bulkheads, decks, ceilings or linings which comply with the following; they shall :

- (a) be constructed as to be capable of preventing the passage of flame to the end of the first one-half hour of the standard fire test;
- (b) have an insulation value such that the average temperature of the unexposed side will not rise more than 139 degrees celsius above the original temperature, nor will the temperature at any one point, including any joint, rise more than 225 degrees celsius above the original temperature, within the time listed below;
 - (i) Class "B-15" 15 minutes
 - (ii) Class "B-0" 0 minutes; and
- (c) be constructed of approved non-combustible materials and all materials entering into the construction and erection of "B" class divisions shall be non-combustible with the exception that combustible veneers may be permitted provided they meet the relevant requirements of Chapter VI.

The Authority may require a test of a prototype division to ensure that it meets the above requirements for integrity and temperature rise.

"Cclass divisions" are those divisions constructed of approved non-combustible materials. They need meet no requirements relative to the passage of smoke and flame not the limiting of temperature rise. Combustible veneers are permitted provided they meet other requirements of Chapter VI.

"F class divisions" are those divisions formed by bulkheads, decks, ceilings or linings which comply with the following they shall:

- (a) be so constructed as to be capable of preventing the passage of flame to the end of the first one-half hour of the standard fire test; and
- (b) have an insulation value such that the average temperature of the unexposed side will not rise more than 139 degrees celsius above the

original temperature, not will the temperature at any one point, including any joint, rise more than 225 degrees celsius above the original temperature, up to the end of the first one-half hour of the standard fire test;

The Authority may require a test of a prototype division to ensure that it meets the above requirements for integrity and temperature rise.

Continuous “B” class ceilings or linings are those “B” class ceilings or linings which terminate only at an “A” or “B” class division.

2. Application

- (1) Unless expressly provided otherwise, the provisions of these Regulations, shall apply to every registered fishing vessel or fishing vessel required to be registered or licenced in terms of the Merchant Shipping Act, 1951 (Act No. 57 of 1951), of 24 metres in length and over, as follows:
 - (a) New vessels after promulgation of these Regulations;
 - (b) Existing vessels two years after promulgation of these Regulations; and
 - (c) Existing vessel registered anew after promulgation of these Regulations.
- (2) The provisions of these Regulations shall not apply to vessels exclusively used:
 - (a) for sport or recreation;
 - (b) for processing fish or other living resources of the sea;
 - (c) for research and training; or

- (d) as fish carriers

3. **Objects of the Regulations**

- (1) These Regulations gives effect to the Cape Town Agreement.
- (2) Provide for the safety of registered fishing vessels or fishing vessels required to be registered or licensed in terms of the Act.

4. **Exemptions**

- (1) The Authority may exempt any vessel, to which these Regulations apply, which embodies features of a novel kind from any of the requirements of these Regulations, the application of which might seriously impede research into the development of such features and their incorporation in vessels.
- (2) Any such vessel referred to in sub-regulation 1 of this regulation shall, however, comply with safety requirements which, in the opinion of the Authority, are adequate for the service for which it is intended and are such as to ensure the overall safety of the vessel, crew and the environment.
- (3) The Authority may exempt any vessel, to which these Regulations apply, from any of the requirements of these regulations, if it considers that the application is unreasonable and impracticable in view of the distance of the vessel's operating area from its base port, the type of vessel, the weather conditions and the absence of general navigational hazards, provided that it complies with safety requirements which, in the opinion of the Authority, are adequate for the service for which it is intended and are such as to ensure the overall safety of the vessel, crew and the environment.

- (4) The Authority may exempt an existing vessel from any of the requirements of these Regulations ,if it considers that the application is unreasonable in view of the vessels original construction, provided that it complies with safety requirements which, in the opinion of the Authority, are adequate for the service for which it is intended and are such as to ensure the overall safety of the vessel, crew and the environment.

5. Equivalentents

- (1) Where these Regulations require that a particular fitting material, appliance or apparatus, be fitted or carried in a vessel, or that any particular provision be made, the Authority may allow any other fitting, material, appliance or apparatus to be fitted or carried, or any other provision to be made, if it is satisfied that it is at least as effective, for the intended operation, as that required by these Regulations.

6. Repairs, Alterations and Modifications

Existing vessels which undergo repairs, alterations and modifications of a major character and outfitting related thereto shall meet the requirements of these Regulations only to the extent of such repairs, alterations and modifications in so

far as the Authority deems reasonable and practicable.

7. Surveys

Every vessel shall be subject to the surveys specified in regulation 14 of these Regulations.

8. Issue and Format of Local General Safety Certificates

- (1)
 - (a) A Local General Safety Certificate, in a format prescribed by the Authority, shall be issued after the satisfactory survey of a vessel which complies with the applicable requirements of these Regulations.
 - (b) Whenever an exemption is granted to a vessel under, and in accordance with, the provisions of these Regulations, a Safety Exemption Certificate, in a format prescribed by the Authority, shall be issued in addition to the certificate required by paragraph (a) of this regulation.
- (2) The certificates referred to in sub-regulation (1) of this regulation shall be issued either by the Authority or by any person or organization duly authorized by the Authority.
- (3) In every case however, the Authority shall assume full responsibility for the

issuance of the certificate(s).

9. Display of Local General Safety Certificates

Immediately after receipt of the certificate(s) issued in accordance with regulation 8, the owner or master shall cause such certificate(s), or a certified copy thereof, to be conspicuously displayed on board the vessel for the information of all on board and shall cause it to be displayed so long as it remains in force and the vessel remains in use.

10. Duration and Validity of Local General Safety Certificates

- (1) A Local General Safety Certificate shall be issued for a period not exceeding one year.
- (2) If at the time when the validity of its certificate expires or ceases, a vessel is not in a South African port, the validity of the certificate may be extended by the Authority for a period not longer than five months, but such extension shall be granted only for the purpose of allowing the vessel to complete its voyage to a South African port or to a port in which it is to be surveyed and then only in cases where it appears proper and reasonable to do so.
- (3) A vessel to which such extension is granted shall not on its arrival in a South African port, be entitled by virtue of such extension to leave such port without having obtained a new certificate.

- (4) A certificate which has not been extended under the provisions of sub-regulation (2) of this regulation may be extended by the Authority for a period of up to one month from the original date of expiry stated on it.
- (5) The extensions referred to in sub-regulation (2) and (4) of this regulation shall be applied for before the expiry date indicated on the vessel's safety certificate.
- (6) No extension may be granted if a safety certificate has ceased to be valid at the time of such application for an extension
- (7) A certificate that expires while a vessel is at sea remains valid until the next arrival in a port.

- (8) When any alteration or addition is contemplated for a vessel which is provided for in these regulations, prior approval is to be obtained from the Authority before any such alteration is commenced. Failure to comply with this requirement may invalidate the Local General Safety Certificate.

11. Cancellation of Local General Safety Certificates

- (1) The Authority may direct that a local general safety certificate be cancelled if by reason of the contents of a report by a surveyor, or for any other reason, it is satisfied that:
 - (a) it was obtained fraudulently or on wrong information;

 - (b) since it was issued, the hull, equipment or machinery of the vessel has, by reason of any alteration made thereto, or by reason or any damage sustained by the vessel, or for any other reason, become insufficient;

- (c) since it was issued, the vessel has for any reason become unseaworthy;
or,
 - (d) the vessel no longer complies with all the requirements of these regulations, the radio Regulations, the collision regulations or any other applicable regulations which may have been made, to the same extent to which she complied with those regulations when the certificate was issued.
- (2) For the purposes of this regulation, the word “alteration” in relation to the hull, equipment or machinery of a vessel, includes the renewal of any part thereof.
 - (3) Whenever a direction is issued under sub-regulation (1) of this regulation for the cancellation of a safety certificate, the Authority shall, in writing, notify the owner or master of the vessel in respect of which the certificate was issued of the cancellation.

12. Designated Person Ashore

- (1) To ensure the safe operations of each vessel and to provide a link between the company and those on board, every owner shall designate a person ashore having direct access to the highest level of management.
- (2) The responsibility and authority of the designated person in terms of sub-regulation (1) of this regulation shall include monitoring the safety and pollution aspects of the operation of each ship and to ensure that adequate resources and shorebased support are applied, as required.
- (3) The appointment of the designated person shall be confirmed in writing to the Authority and that person’s name and contact particulars shall be prominently displayed in the wheelhouse of the vessel.

- (4) The designated person shall also be responsible for compliance with regulation 39A of the Maritime Occupational Safety Regulations, 1994.

13. On Board Safety Officers

- (1) To ensure safe operations on board each vessel and to provide a link between the vessel and the designated person ashore, every owner shall designate a person on board the vessel to have direct access to the person referred to in regulation 12.
- (2) The appointment of the onboard safety officer shall be confirmed in writing by the company and owner.
- (3) The onboard safety officer shall ensure that all safety aspects of the vessel shall be carried out in a safe manner.
- (4) The designated onboard safety officer shall undergo approved training and shall conduct his other duties in accordance with the Maritime Occupational Safety Regulations, 1994.
- (5) The duties of the safety officer shall not be impeded by the master or any other person of any vessel and he or she shall not be prevented from having direct access to the person referred to in regulation 12 for any reason whatsoever.

CHAPTER II SURVEYS

14. General

- (1) (a) An initial survey shall be required before a fishing vessel is put into service or before the certificate required under regulation 8 of this Regulations is issued for the first time;
 - (b) The surveys shall include a complete survey of the vessels structure, stability, machinery, arrangements and material, including the inside and outside of the vessels hull and boilers and associated equipment in so far as the vessel is covered by these Regulations; and
 - (c) The survey shall be such as to ensure that the arrangements, material and scantlings of the structure, boilers, other pressure vessels and their appurtenances, main and auxiliary machinery, electrical installations, radio installations, including those used in life-saving equipment appliances, fire protection, fire safety systems and appliances, life-saving appliances and arrangements, shipborne navigational equipment, nautical publications and other equipment fully comply with the requirements of these Regulations.
- (2) Thereafter, an annual survey of the vessel shall be carried out to ensure continued compliance with requirements of these Regulations.
 - (3) Specific survey items which do not necessarily require an annual survey are described in regulations (15) to (25) of this Chapter.
 - (4) The local general safety certificate required by Regulation 8 of these Regulations, shall be issued on completion of the following surveys, to the satisfaction of the Authority:
 - (a) Hull Survey an annual or biennial survey of the applicable structure and machinery of the vessel referred to in Chapters II to X of these Regulations;

- (b) Radio Survey an annual survey of the vessels radio equipment as required by the Merchant Shipping (Radio) Regulations, 2002;and
 - (c) Safety Survey an annual survey of the applicable machinery, systems, lifesaving equipment and procedures referred to in chapters II to XI of these Regulations.
- (5) Where a survey of a fishing boat is required, the owner shall address a request for inspection to the proper officer in order to give at least two working days' notice of the required service.
- (6) If any part of the vessel, its machinery or equipment is found by the surveyor to be not in a satisfactory condition, or not complying with any part of these Regulations or any item considered to be unsafe, any repairs or renewals which the surveyor considers necessary shall be carried out to the satisfaction of the surveyor and if required, to be inspected by the surveyor.

15. Hull

- (1) Subject to sub-regulation (5) of this regulation, fishing vessels shall every twelve months be placed in dry-dock or on a slipway for inspection by a surveyor.
- (2) The hull shall be inspected as follows:
- (a) The surveyor shall examine the hull externally and internally after it has been cleaned down but not painted;and
 - (b) All closing appliances for deck openings and all coamings, ventilators, air pipes and deckhouses shall be thoroughly examined by the surveyor.
- (3) Any part which the surveyor requires to be removed in order that the condition of the hull, be ascertained shall be removed.

- (4) Thickness testing on steel vessels shall normally be carried out after a vessel has been in service for 10 years and thereafter every 6 years, however thickness testing may be required where and as considered necessary by the surveyor.
- (5) Owners may apply to the Authority for an extension of one year between hull surveys, if their vessel is constructed of a material other than wood. Written application for such an extension must be made to the Authority before the survey is carried out, and must be accompanied by:
- (a) Appropriate supporting information demonstrating that the owner has in place a suitable regime to the satisfaction of the Authority and this supporting information includes but not limited to ;
- (i) Hull Thickness records;
 - (ii) Cathodic protection arrangements; and
 - (iii) Adequate paint protection system;
- (b) Approval of the one year extension shall be subject to the provision of the above information and the recommendation of the attending surveyor.

16. Tanks

- (1) Tanks forming part of the hull structure shall be inspected by the surveyor as is tabled below. Tanks not examined internally may be examined externally from accessible boundaries:

| Fluid Contained in Tank | Age of Ship in years | | | |
|--|----------------------|-------------------|--------------------|---------------|
| | Age \leq 5 | 5 < Age \leq 10 | 10 < Age \leq 15 | Age \leq 15 |
| Sea Water (S/W) | All | All | All | All |
| S/W & Fresh Water Incorporated | None | One | All | All |
| SW & Fuel diesel oil incorporated | Half | Half | Half | half |
| Independent Tanks - Fresh water, Lubricating Oil or Diesel Oil. | None | None | Half | half |

- (2) The survey of tanks as required by sub-regulation (1) of this regulation should be spread over a 5 year period i.e. not all at one survey. Tanks not examined internally may be examined externally from accessible boundaries.
- (3) Where considered necessary, thickness testing or pressure testing of double bottom or peak tanks shall be carried out to the satisfaction of the surveyor.
- (4) Where pressure testing of tanks is carried out, they shall be tested by hydraulic pressure to a head not less than the maximum to which the tank can be subjected or 2.4 metres above the tank whichever the great is.

17. Shafts and Rudders

- (1) Propeller shafts shall be withdrawn for inspection by the surveyor as follows:
- (a) steel, water lubricated shafts; every three years;
 - (b) Stainless steel, bronze or monel shafts or shafts fitted with continuous liners, water/grease lubricated; every four years;and
 - (c) Shafts operating in sealed oil lubricated systems; every four years provided that this period may be extended to a maximum of ten years provided that;

- (i) an independent analysis of the stern tube lubricating medium is carried out annually for the first four years and at six monthly intervals thereafter;
 - (ii) a log showing the stern tube lubrication oil consumption is maintained; and,
 - (iii) a record of the shaft wear-down or shaft clearances is taken at each annual or biennial docking.
- (2) Controllable pitch propellers shall be maintained in accordance with the manufacturer's specifications. In the absence of the manufacturer's specifications to the satisfaction of the surveyor.
- (3) The surveyor may require that propeller(s) be removed, shaft crack testing be carried out and the fit of the shaft tapers be witnessed and that shaft clearances be measured.
- (4) The rudder and rudder stock shall be dismantled at the same time that the shaft is drawn as required by sub-regulation (1) of this regulation, provided that the rudder stock need not be dismantled if records of rudder bearing clearances and oil consumption have been maintained to the satisfaction of the surveyor.
- (5) The surveyor may require shaft(s) to be drawn or rudder(s) and rudder stock(s) dismantled for inspection at any survey, if it is considered necessary.

18. Sea Connections

- (1) All sea connections, suction, discharge valves and cocks shall every two years be opened up for inspection by a surveyor while the hull is being surveyed externally.
- (2) At intermediate surveys the surveyor shall examine all sea connection fastenings

and, if considered necessary, may require any valve or cock to be opened for inspection.

- (3) Scuppers and offal chutes located on the factory deck which form part of the enclosed volume of the vessel shall also be regarded as sea connections the bodies and closing mechanisms shall be inspected in accordance with sub-regulation (1) of this regulation.

19. Anchors, Cables, Wires and Steering Chains

- (1) Every twelve months, the vessels anchors, cables, windlass and steering chains (if any) shall be inspected and may be operationally tested by the surveyor.
- (2) Anchor cables shall be ranged for inspection by the surveyor eight years after construction of the vessel and thereafter at intervals of four years.
- (3) Where anchor cables or steering chains are worn to such an extent that the mean diameter of any part is reduced by more than 12% of the minimum size detailed in regulation 46 of these Regulations, then such part shall be renewed.
- (4) Anchor wire ropes, if used, shall be run out annually for inspection by the surveyor.
- (5) No anchor wire rope shall be used if in any length of 8 diameters the total number of visible broken wires exceeds 10 per cent of the total number of wires, or the rope shows signs of excessive wear, corrosion or other defect which, in the opinion of the surveyor, renders it unfit for use.

20. Steering Gear and Emergency Arrangements

- (1) The steering gear and emergency steering arrangements shall be examined by the surveyor every twelve months and the correct operation of the arrangements shall be demonstrated to the satisfaction of the surveyor.
- (2) The emergency steering arrangements shall have the instructions for operating that system clearly posted and valves labelled where required.

21. Boilers which permit a full internal examination

- (1) A boiler being a fire-tube steam generator, which permits a full internal examination shall be surveyed every 12 months and shall before survey commences, be completely prepared for survey, and all parts shall be thoroughly cleaned to the satisfaction of the surveyor or an approved inspection authority.
- (2) Boiler mountings shall be opened up and cleaned and all valves lapped to the respective valve seat.
- (3) Any part which prevents proper examination of the boiler, shall be removed and the boiler shall be lifted if the surveyor or an approved inspection authority considers a further examination of the underside thereof necessary.
- (4) Lagging shall be removed if the surveyor considers it necessary.
- (5) The boiler being a fire-tube steam generator, shall be hydraulically tested to 1.25 times working pressure every three years and critical welds subjected to crack detection: Provided that if major repairs are effected to the boiler, it shall be so tested immediately upon completion of such repairs.
- (6) Every pressure vessel and steam generator, excluding those referred to in sub-regulations (1) to (5), to be subjected to an internal and external inspection and a

hydraulic test to a pressure of 1,25 times the design pressure by a surveyor or an approved inspection authority at intervals not exceeding 36 months:

- (7) Safety valves shall be reset to the correct operating pressure by an approved inspection authority or suitably qualified person who shall provide the owner with a certificate confirming the work carried out.
- (8) The approved inspection authority and surveyor shall ensure that means are provided to prevent subsequent tampering with the adjustment of the valves.

22. Boilers which do not permit a Full Internal Examination

- (1) Boilers, pressure vessels and steam generators referred to in regulation 21 of these Regulations, which do not permit a full internal examination, shall be dealt with in accordance with the provisions of regulation 21 of these Regulations, provided that such boilers shall every 12 months be hydraulically tested to 1.25 times working pressure.

23.

- (1) Subject to the provisions of sub-regulations (2) and (3) of this regulation, main steam pipes and auxiliary steam pipes with an internal diameter of over 75 mm shall, in the presence of the surveyor or an approved inspection authority or, be tested by hydraulic pressure to twice (2 times) the working pressure at the following intervals -
 - (a) pipes of steel, or solid drawn copper, every six years;or
 - (b) copper pipes having brazed longitudinal seams every four years.
- (2) At the time of the tests prescribed in sub-regulation (1) of this regulation or at any

other time if it is deemed necessary, the surveyor shall examine the pipes thoroughly, and any pipe shall be removed and hydraulically tested at any time if there is reason to believe that its condition is unsatisfactory.

- (3) If the surveyor considers it necessary, copper pipes shall be annealed, and this shall generally be done at the time of the hydraulic tests.

24. Main and Auxiliary Machinery

- (1) The surveyor may require that a running trial of the main and auxiliary machinery be held every 12 months to the satisfaction of the surveyor.
- (2) The correct operation of air compressor(s), air receiver(s) and any other pressure relief valves shall be demonstrated to the satisfaction of the surveyor every 12 months.

25. Air Receivers and Pressure Vessels

- (1) Air receivers and pressure vessels shall be hydraulically tested to a pressure of 1.25 times their working pressure, every four years.
- (2) All mountings, valves, controls, indicators, gauges and safety devices shall be overhauled once every four years.
- (3) Pressure relief valves shall be calibrated and reset to their operating pressures.
- (4) The work required by sub-regulations (1), (2) and (3) of this regulation shall be carried out by an approved person who shall provide the owner with a certificate confirming compliance with this Regulation.

26. Refrigeration Systems used for the Preservation of Catch

- (1) Refrigeration systems used for the preservation of catch shall be pressure tested every 4 years, with Nitrogen, to 1.25 times their working pressure.
- (2) The entire refrigerant system, with the exception of the receiver shall be pressure tested.
- (3) The receiver shall be externally examined by the surveyor every 4 years and if the receiver appears not to be in good condition, the surveyor may require that it be hydraulically pressure tested to 1.25 times working pressure.
- (4) The work required by sub-regulations (1) to (3) of this regulation shall be carried out by an approved person who shall provide the owner with a certificate confirming compliance with this Regulation.

27. Electrical Equipment

- (1) The electrical equipment of vessels may be examined by the surveyor at every survey.
- (2) An insulation test shall be carried out on all electrical circuits and machinery of greater than 50 Volts, every four years and the resistance between all insulated circuits and earth shall be not less than 100,000 ohms.
- (3) The generator circuit breakers, over-current protective devices and fuses shall be examined to verify that they will operate satisfactorily.

- (4) The work required by sub-regulations (1) to (3) of this regulation shall be carried out by a suitably qualified person who shall provide the owner with a certificate confirming compliance with this Regulation.

CHAPTER III

CONSTRUCTION, WATERTIGHT INTEGRITY AND EQUIPMENT

28. Submission & Approval of Plans

- (1) Before the construction of any ship is commenced or at an early stage thereafter, the builder or owner thereof shall submit in duplicate to the Authority the plans and particulars set forth in Annex 1 of these Regulations for approval.
- (2) If the vessel is an existing vessel, coming on to the Register, the owner shall submit in duplicate to the Authority the plans and particulars set forth in Annex 1 of these Regulations, to the satisfaction of the Authority, for approval.
- (3) The Authority may call for the submission of additional or more detailed plans or particulars, and may also waive the requirements that certain plans be submitted.
- (4) Some of plans required by sub-regulations (1) and (2) of this regulation may also be combined, if the vessels size or simplicity of construction allows this.
- (5) Any subsequent proposed modifications, alterations or additions to the scantlings, arrangements or equipment shall be shown on approved plans or particulars shall be submitted to the Authority for re-approval.

CHAPTER II

- (6) If a vessel is constructed and presented to the Authority for registration and inspection without the provision of plans and particulars required by sub-regulations (1) or (2) of this regulation, the Authority may refuse to proceed with registration or the issue of safety certification, as required by regulation 8 of these Regulations, for the vessel.
- (7) If modifications, alterations or additions to the scantlings, arrangements or equipment shown on approved plans and particulars are carried out without the approval of the Authority, the vessels safety certificate, as required by regulation 8 of these Regulations, may be cancelled.

29. Inspections, Tests and Surveys of New Constructions

- (1) During the construction and inspections tests shall be carried out by the surveyor to ensure that the vessel is constructed in accordance with:
- (a) the approved plans and particulars required by regulation 28 of these Regulations; and,
 - (b) the requirements of these Regulations.
- (2) The builder or owner shall notify the Authority at least 1 week in advance of:
- (a) commencement of framing;
 - (b) commencement of planking, plating or laminating;
 - (c) completion of the fitting of all underwater fittings, rudder, stern tube, shaft and propeller; and
 - (d) the proposed launching date.

- (3) In the event of the Authority not being notified in accordance with sub-regulation (2) of this regulation, the Authority may require that any work be carried out to establish that the vessel's construction is satisfactory and in accordance with approved plans and particulars.
- (4) The dock and sea trials shall be carried out in the presence of the surveyor, at which time the pumping arrangements, steering gear, main and auxiliary machinery shall be tested to the satisfaction of the surveyor.
- (5) Any such further tests as the surveyor may consider necessary to determine whether the vessel is safe and suitable for the purpose that it is intended shall be carried out to the satisfaction of the surveyor.

30 Construction and Structural Strength

- (1) Strength and construction of hull, superstructures, deckhouses, machinery casings, companionways and any other structures and vessel's equipment shall be sufficient to withstand all foreseeable conditions for the vessel's intended service and shall be to the satisfaction of the Authority.
- (2) A vessel may be constructed of wood, fibre reinforced plastic, aluminium alloy or steel or combinations of such materials.
- (3) Proposals to use any other construction material shall be submitted to the Authority for approval.
- (4) The hull of a new vessel shall be considered to be of adequate strength after satisfactory examination by a surveyor of the Authority or a person authorised by

the Authority and if it has been built in accordance with the hull construction rules of a Classification Society, Code or Standard recognised by the Authority, in which case the design must be endorsed by the society or organisation.

- (5) If a vessel is not intended to be built in accordance with sub-regulation (4) of this regulation it may be specially considered, provided that full information (including calculations, drawings, details of materials and construction), endorsed by a naval architect or professional engineer are submitted to the Authority for approval.
- (6) The hull of an existing vessel may be considered to be of adequate strength if it is in a good state of repair and;
 - (a) has been built to one of the standards described in sub-regulations (4) or (5); or,
 - (b) has a record, to the satisfaction of the Authority, of safe operation in sea and weather conditions considered to be of no less severe than those likely to be encountered by the vessel.
- (7) The hull of vessels intended for operation in ice shall be strengthened in accordance with the rules of an approved classification society for the anticipated conditions of navigation and area of operation.

31. Bulkheads and Double Bottoms

- (1) Bulkheads, closing devices and closures of openings in these bulkheads, as well as methods for their testing, shall be in accordance with the requirements of these Regulations.

- (2) Vessels constructed of material other than wood shall be fitted with a collision bulkhead and at least with watertight bulkheads bounding the main machinery space and such bulkheads shall be extended up to the working deck.
- (3) In vessels constructed of wood such bulkheads, shall also be fitted and shall be watertight.
- (4) Pipes piercing the collision bulkheads shall be fitted with suitable valves operable from above the working deck and the valve chest shall be secured at the collision bulkhead inside the forepeak.
- (5) No door, manhole, ventilation duct or any other opening shall be fitted in the collision bulkhead below the working deck.
- (6) Where a long forward superstructure is fitted, the collision bulkhead shall be extended weathertight to the deck next above the working deck.
- (7) The extension referred to in sub-regulation (6) of this regulation need not be fitted directly over the bulkhead below provided it is located within the limits given in regulation 1(10) of these Regulations and the part of the deck which forms the step is made effectively weathertight.
- (8) The number of openings in the collision bulkhead above the working deck shall be reduced to the minimum compatible with the design and normal operation of the vessel.
- (9) Openings referred to in sub-regulation (8) of this regulation shall be capable of being closed weathertight.
- (10) In vessels of 75 metres in length and over, a watertight double bottom shall be fitted, as far as practicable, between the collision bulkhead and the after peak

bulkhead.

32. Watertight Doors

- (1) The number of openings in watertight bulkheads shall be reduced to the minimum compatible with the general arrangements and operational needs of the vessel.
- (2) Openings shall be fitted with watertight closing appliances to the satisfaction of the Authority.
- (3) Watertight doors shall be of an equivalent strength to the adjacent unpierced structure.
- (4) In vessels of less than 45 metres in length, such doors may be of the hinged type, which shall be capable of being operated locally from each side of the door and shall normally be kept closed at sea.
- (5) A notice shall be attached to the door on each side to state that the door shall be kept closed at sea.
- (6) In vessels of 45 metres in length and over, watertight doors shall be of the sliding type in:
 - (a) spaces where it is intended to open them at sea and if located with their sills below the deepest operating waterline; and,
 - (b) the lower part of a machinery space where there is access from it to a shaft or pipe tunnel.

Otherwise watertight doors may be of the hinged type.

- (7) Sliding watertight doors shall:

- (a) be capable of being operated when the vessel is listed up to 15 degrees to port or starboard;
- (b) whether manually operated or otherwise shall be capable of being operated locally from each side of the door and by remote control from an accessible position above the working deck except when the doors are fitted in the crew accommodation spaces; and,
- (c) be provided with indication at remote operating positions to clearly show when the doors are open or closed.

33. Watertight integrity

- (1) Openings through which water can enter the vessel shall be provided with closing devices in accordance with the applicable provisions of these Regulations and to the satisfaction of the Authority.
- (2) Deck openings which may be open during fishing operations shall normally be arranged near to the vessel's centreline, however, the Authority may approve alternative arrangements if satisfied that the safety of the vessel will not be impaired.
- (3) Stockerpond hatches shall be able to be closed weathertight.
- (4) Stockerpond hatches shall be power-operated and capable of being controlled from any position which provides an unobstructed view of the operation of the hatch.
- (5) Bypass arrangements shall be fitted to hydraulic systems to allow manual closing of fish flaps.
- (6) Weathertight closing devices shall be fitted between the stocker pond and the

factory or fish processing area if below the working deck

34. Weathertight Doors

- (1) All access openings in bulkheads of enclosed superstructures and other outer structures through which water could enter and endanger the vessel, shall be fitted with doors permanently attached to the bulkhead, framed and stiffened so that the whole structure is of equivalent strength to the unpierced structure, and weathertight when closed.
- (2) The means for securing these doors weathertight shall consist of gaskets and clamping devices or other equivalent means and shall be permanently attached to the bulkhead or to the doors themselves, and shall be so arranged that they can be operated from each side of the bulkhead.
- (3) The height above deck of sills in those doorways, in companionways, erections and machinery casings which give direct access to parts of the deck exposed to the weather and sea shall be at least 600 millimetres on the working deck and at least 300 millimetres on the superstructure deck.
- (4) Where operating experience has shown justification and on approval of the Authority, these heights, except in the doorways giving direct access to machinery spaces, may be reduced to not less than 380 millimetres and 150 millimetres respectively.
- (5) Weathertight doors shall be permanently marked with notices to the effect that the doors should be kept closed at sea.

35. Hatchway Closed by Wood Covers

- (1) The height above deck of hatchway coamings shall be at least 600 millimetres on exposed parts of the working deck and at least 300 millimetres on the

- superstructure deck.
- (2) Where operating experience has shown justification and on the approval of the Authority the height of these coamings may be reduced, or the coamings omitted entirely, provided that the safety of vessels is not thereby impaired.
 - (3) In this case the hatchway openings shall be kept as small as practicable and the covers be permanently attached by hinges or equivalent means and be capable of being rapidly closed and battened down.
 - (4) For the purpose of strength calculations, it shall be assumed that hatchway covers are subjected to the weight of cargo intended to be carried on them or the following static loads, whichever is the greater:
 - (a) 10.0 KiloNewtons per square metre for vessels of 24 metres in length; or
 - (b) 17.0 kiloNewtons per square metre for vessels of 100 metres in length and over;
 - (5) For intermediate lengths, the load values shall be determined by linear interpolation.
 - (6) The Authority may reduce the loads to not less than 75 percent of the above values for covers to hatchways situated on the superstructure deck in a position abaft a point located 0.25L from the forward perpendicular.
 - (7) Where covers are made of mild steel, the maximum stress calculated according to sub-regulation (4) of this regulation multiplied by 4.25 shall not exceed the minimum ultimate strength of the material.
 - (8) Under these loads the deflections shall not be more than 0.0028 times the span.
 - (9) Covers made of materials other than mild steel shall be at least of equivalent

strength to those made of mild steel, and their construction shall be of sufficient stiffness ensuring weathertightness under the load specified in sub-regulation 4 of this regulation.

- (10) Covers shall be fitted with clamping devices and gaskets sufficient to ensure weathertightness, or other equivalent arrangements to the satisfaction of the Authority.

36. Factories

- (1) Any openings in the shell plating providing access to a factory which forms part of the enclosed volume of a vessel shall be provided with efficient and readily accessible means for preventing the accidental admission of water unless it can be shown that the vessels intact stability is not adversely affected by such opening(s).
- (2) Without prejudice to the generality of subregulation (1) of this regulation, the following is applicable to factories that form part of the enclosed volume of the vessel:
- (a) Scuppers shall be able to be closed weather tight.
 - (b) As a minimum, a non-return arrangement shall be fitted with a positive means of closing at the local position. If a scupper opening is such that water ingress into the vessel is possible before an angle of heel of 40 degrees is reached, then a remote position at least one deck above the factory compartment shall be fitted with openorclosed indication.
 - (c) Offal chutes shall be able to be closed weather tight. As a minimum,

two means of closing shall be provided with one means of closing being in the form of a non-return arrangement which can be positively secured in the open and closed position. If an offal chute opening is such that water ingress into the vessel is possible before an angle of heel of 40 degrees is reached, with the vessel in its deepest operational load condition, a positive means of closing shall be provided at a remote position at least one deck above the factory compartment fitted with open/close indication.

- (d) Linehauler recovery stations shall be separate from the factory area and all accesses and openings between the station and factory shall be able to be closed weathertight.
- (e) Accesses from the factory deck used for the loading of fish or crew access to compartments below the factory deck shall be of minimum size and number consistent with the fishing operation. These accesses shall:
 - (i) be able to be closed weathertight quickly and efficiently;
 - (ii) be provided with sills or coamings of at least 600 millimetres height. Where operating experience has shown justification and on approval of the Authority, these heights, except in the doorways giving direct access to machinery spaces, may be reduced to not less than 380 millimetres; and,
 - (iii) be located as close to the centreline as is practicably possible.
- (f) If washing water in the factory is removed using dill pumps:
 - (i) wash pumps shall be configured so that they are unable to

operate unless automatically operated dill pumps of at least 50% greater capacity are in operation; and

(ii) a minimum of one dill pump on the port and starboard side shall be provided to the satisfaction of the Authority. Dill pumps shall be of suitable design and capacity and capable of handling offal and solids that could be expected during normal fishing operations.

- (3) Owners and masters shall ensure that standard operating procedures are in place to ensure that all openings in the shell plating, required to be closed, are closed and that washing water pumps are off when the factory compartment is unattended by competent persons.

37. Machinery Space Openings

- (1) Machinery space openings shall be framed and enclosed by casings of a strength equivalent to the adjacent superstructure.
- (2) External access openings and openings providing access from factory decks which form part of the enclosed volume shall be fitted with doors and sills complying with the requirements of sub-regulation 34.
- (3) Openings other than access openings shall be fitted with covers of equivalent strength to the unpierced structure, permanently attached thereto and capable of being closed weathertight.

38. Other Deck Openings

- (1) Where it is essential for fishing operations, flush deck scuttles of the screw, bayonet or equivalent type and manholes may be fitted provided these are capable of being closed watertight and such devices shall be permanently attached to the adjacent structure.
- (2) Having regard to the size and disposition of the openings and the design of the closing devices, metal-to-metal closures may be fitted if the Authority is satisfied that they are effectively watertight.
- (3) Openings other than hatchways, machinery space openings, manholes and flush scuttles in the working or superstructure deck shall be protected by enclosed structures fitted with weathertight doors or their equivalent. Companionways shall be situated as close as practicable to the centreline of the vessel.

39. Testing of Watertight and Weathertight Compartments

- (1) The bulkheads of a wooden or fibre reinforced plastic vessels, which are required to be watertight, shall before the vessel is launched, be tested to the satisfaction of the surveyor, pressure test or other suitable means.
- (2) Before a steel vessel is launched, the compartments within the main hull shall, before any cementing is commenced, be subjected to pressure tests as follows -
 - (a) double bottoms which are not to be used for the carrying of oil, shall be tested to a head of water equal to the maximum head which can be expected in service;
 - (b) deep tanks and peak tanks used for carrying water, and deep tanks and double bottom tanks arranged for carrying oil fuel, shall be

tested to a head of water equal to the maximum head to which the tanks can be subjected in service, but not less than 2.4 m above the crowns of the tanks where the moulded depth to the upper deck exceeds 4.8 m, and 900 mm where the moulded depth does not exceed 3 m. Intermediate heads may be obtained by interpolation;

- (c) peak bulkheads which do not form the boundaries of tanks, shall be tested by filling the peaks with water; and,
 - (d) watertight bulkheads, including recesses and watertight flats, watertight tunnels, weather decks and waterways, shall be either visually inspected, non-destructive tested or pressure tested to the satisfaction of the surveyor.
- (3) The correct operation of watertight and weathertight doors, and hatches shall be proven at the time of vessel construction and at subsequent surveys.

40. Ventilators

- (1) Ventilators shall be sufficient in number and size to provide adequate ventilation for all spaces which, in the opinion of the surveyor, require ventilation.
- (2) In vessels of 45 metres in length and over, the height above deck of ventilator coamings, other than machinery space ventilator coamings, shall be at least 900 millimetres on the working deck and at least 760 millimetres on the superstructure deck.
- (3) In vessels of less than 45 metres in length, the height of these coamings shall be 760 millimetres and 450 millimetres respectively.
- (4) The height above deck of machinery space ventilator openings shall be to the satisfaction of the Authority.

- (5) Coamings of ventilators shall be of equivalent strength to the adjacent structure and capable of being closed weathertight by closing appliances permanently attached to the ventilator or adjacent structure.
- (6) Where the coaming of any ventilator exceeds 900 millimetres in height it shall be specially supported.
- (7) Ventilators shall be provided with a suitable means of closing secured to the ventilator or adjacent to it.

41. Air Pipes

- (1) Where air pipes to tanks and void spaces below deck extend above the working or the superstructure decks, the exposed parts of the pipes shall be of a strength equivalent to the adjacent structures and fitted with appropriate protection. Openings of air pipes shall be provided with automatic means of closing.
- (2) The height of air pipes above deck to the point where water may have access below shall be at least 760 millimetres on the working deck and at least 450 millimetres on the superstructure deck.
- (3) Fuel air pipes shall be fitted with anti-flash gauze, \square max = 0.5mm, of steel or ceramic material.

42. Sounding Pipes and Devices

- (1) Sounding pipes or devices, to the satisfaction of the Authority, shall be fitted:
 - (a) to the bilges of those compartments which are not readily accessible at all times during the voyage; and
 - (b) to all tanks and cofferdams.
- (2) Sounding pipe upper ends shall be extended to a readily accessible position and, where practicable, above the working deck.
- (3) The openings of sounding pipes shall be provided with permanently attached means of closing.
- (4) Sounding pipes to double bottom tanks or tanks which form part of the hull structure which are not extended above the working deck shall be fitted with automatic self-closing devices.
- (5) Striker plates shall be welded in tanks directly below the outlets of sounding pipes, provided that the Authority may accept alternative arrangements which prevent the shell plating from being damaged when tanks are sounded.

43. Side Scuttles and Windows

- (1) Side scuttles to spaces below the working deck and to spaces within the enclosed structures on that deck shall be fitted with hinged deadlights capable of being closed watertight.

- (2) Side scuttles fitted above the working deck which are less than 1000 millimetres from the deepest operating waterline shall be fitted with hinged deadlights capable of being closed watertight.
- (3) No side scuttle shall be fitted in such a position that its sill is less than 500 millimetres above the deepest operating waterline.
- (4) Side scuttles, fitted less than 1000 millimetres above the deepest operating waterline shall be of a fixed type.
- (5) Side scuttles together with their glasses and deadlights shall be of an approved construction. Those prone to be damaged by fishing gear shall be suitably protected.
- (6) Solid toughened glass of not less than 6.35 mm thickness shall be fitted to wheelhouse windows of up to 760 mm square clear light size.
- (7) For greater window sizes a minimum glass thickness of 9.5 mm shall be provided.

44. Inlets and Discharges

- (1) Valves or cocks shall be fitted to all suction and discharge pipes which pass through the hull below the upper deck, provided that this regulation shall not apply to:
 - (a) Pump discharges of 38 mm or less which are situated above the deepest operating waterline;
 - (b) keel cooling systems which form an integral part of the hull; and

- (c) scuppers which pass from the upper deck to the ships side above the deepest operating waterline.
- (2) Discharge valves shall normally be fitted with an automatic non-return valve with means of positive closing from an accessible position provided that such valves may not be required if the Authority is satisfied that entry through the opening is not likely to lead to dangerous flooding and the thickness of piping is sufficient.
- (3) Suction and discharge valves and cocks shall be secured to the hull or to fabricated sea chests such that the securing arrangement is at least as strong as the surrounding structure, to the satisfaction of the authority.
- (4) Valves or cocks shall be fitted as close to the hull as possible.
- (5) Where a threaded valve and flanged pipe arrangement is used, schedule 40 piping shall be used subject to a minimum pipe wall thickness of 3mm, and not exceeding 200 mm in length.
- (6) Valves or cocks shall be fitted in accessible positions and shall be arranged in such a manner that it can be readily seen whether they are open or closed.
- (7) The handles of valves or cocks shall not be removable in the open position.
- (8) Due regard shall be paid to compatibility of materials used in order that galvanic action be minimised.

45. Freeing Ports

- (1) Where bulwarks on weather parts of the working deck form wells, the minimum freeing port area (A) in square metres, on each side of the vessel for each well

on the upper deck shall be determined in relation to the length (l) and height of bulwark in the well as follows:

- (a) $A = 0.07l$ (l need not be taken as greater than $0.7L$).
 - (b) (i) Where the bulwark is more than 1200 millimetres in average height the required area shall be increased by 0.004 square metres per metre of length of well for each 100 millimetres difference in height.
 - (ii) Where the bulwark is less than 900 millimetres in average height, the required area may be decreased by 0.004 square metres per metre of length of well for each 100 millimetres difference in height.
- (2) The freeing port area calculated according to sub-regulation (1) of this regulation shall be increased where the Authority considers that the vessel's sheer is not sufficient to ensure that the deck is rapidly and effectively freed of water.
 - (3) Subject to the approval of the Authority the minimum freeing port area for each well on the superstructure deck shall be not less than one-half the area (A) given in sub-regulation (1) of this regulation.
 - (4) Freeing ports shall be so arranged along the length of bulwarks as to ensure that the deck is freed of water most rapidly and effectively.
 - (5) Lower edges of freeing ports shall be as near the deck as practicable.
 - (6) Pound boards and means for stowage of the fishing gear shall be arranged so that the effectiveness of freeing ports will not be impaired.
 - (7) Pound boards shall be so constructed that they can be locked in position when in use and shall not hamper the discharge of shipped water.
 - (8) Freeing ports over 300 millimetres in depth shall be fitted with bars spaced not more than 230 millimetres nor less than 150 millimetres apart or provided with

other suitable protective arrangements.

- (9) Freeing port covers, if fitted, shall be of approved construction. If devices are considered necessary for locking freeing port covers during fishing operations they shall be to the satisfaction of the Authority and easily operable from a readily accessible position.
- (10) In vessels intended to operate in areas subject to icing, covers and protective arrangements for freeing ports shall be capable of being easily removed to restrict ice accretion.
- (11) The size of openings and means provided for removal of these protective arrangements shall be to the satisfaction of the Authority.
- (12) On vessels with partially or fully exposed weather decks, no bilge/dill pumps shall be permitted as a replacement for freeing ports.

46. Anchoring Equipment

- (1) Anchor equipment designed for quick and safe operation shall be provided which shall consist of anchors, anchor chains or wire ropes, stoppers and windlass or other arrangements for dropping and hoisting the anchor and for holding the vessel.
- (2) Every vessel shall be provided with at least two bow anchor which shall be connected and stowed in position, ready for immediate use.
- (3) Anchors are normally to be housed in hawse pipes of suitable size and form to prevent movement of anchor and chain due to wave action.
- (4) The arrangement is to be such that upon the release of the brake, the anchor is immediately to start falling by its own weight.

- (5) At the upper and lower ends of hawse pipes there are to be chafing lips with radius of curvature such that at least 3 links of chain shall bear on the rounded parts.
- (6) Alternatively, roller fairleads of suitable design may be fitted.
- (7) Where hawse pipes are not fitted, alternative arrangements shall be specially considered by the Authority.
- (8) Shell plating in way of the hawse pipes shall be increased in thickness and framing reinforced as necessary to ensure rigid fastening of the hawse pipes to the hull.
- (9) Local reinforcement of bulbous bows, if fitted, shall be provided, as necessary.
- (10) Vessels shall be fitted with windlass, chain and anchor stoppers which are efficiently bedded to the deck.
- (11) Deck plating in way of windlass and chain stoppers shall be thickened and supported by pillars, as necessary.
- (12) Chain lockers shall have adequate capacity and suitable form to provide a proper stowage of the chain cable and an easy lead into the chain pipes when the cable is fully stowed.
- (13) Port and starboard cables shall be provided with separate spaces.
- (14) The chain locker boundaries and access openings are to be watertight and provisions are to be made to prevent the chain lockers from being flooded in adverse weather conditions.
- (15) Adequate drainage facilities from the chain locker(s) are also to be provided. Provisions shall be made for securing the inboard ends of the chain to the structure.
- (16) This attachment shall be able to withstand a force of not less than 15% or more than 30% of the minimum breaking strength of the chain cable.

- (17) The fastening arrangement shall also be such that the chain can be readily slipped in the event of an emergency and anchor and chain have to be sacrificed.
- (18) Anchor equipment shall be provided in accordance with Annex 2 in accordance with the vessels Equipment Number, calculated as follows:

$$EN = \Delta^{2/3} + 2BH + 0.1 A$$

with Δ = Vessels deepest operational displacement in tonnes.

BH = Bow-on element

with B = Vessel Breadth, and;

$$H = a + \sum h_i$$

with a = distance (m) from the deepest operating waterline amidships to the deck at side, and;

h_i = mean height (m) of superstructures and deck houses having a breadth greater than B/4, measured from the upper deck.

A = Profile element

with A = Area (m²) in profile view of the hull, superstructures and houses above the deepest operating waterline. Houses of breadth less than B/4 should be disregarded.

Note: Bulwarks and or wind screens having a height greater than 1.5 metres should be regarded as part of the superstructure and deck houses when determining (H) and (A).

- (19) The total length of chain required by Annex 2 shall be equally divided between the two anchors.

- (20) The mass of the anchors required by Annex 2 shall;
- (a) not vary by more than 7% of the table value if stockless bow anchors are used, provided that the combined mass may not be less than the combined table value. For stockless bower anchors the mass of the head may not be less than 60% of the table value;
 - (b) if a stocked bow anchor is used, the mass may not be less than 80% of the table value. The mass of the stock of stocked bower anchors is to be 25% of the total mass of the anchor, including the shackle, etc., but excluding the stock;
 - (c) if a high holding power (HHP) anchor is used, the mass of the anchor is to be not less than 75% of the table value.
- (21) If steel wire rope is used instead of stud link chain cable, at least the same breaking strength shall be required.
- (22) Between the anchor and the steel wire rope a short length of chain cable is to be fitted.
- (23) The length is to be taken as the smaller of 12.5 m and the distance between the stowed anchor and the winch.
- (24) The anchor weight shall be increased by 25% and the length of steel wire rope is to be at least 50% above the table value for chain cable.
- (25) The wire rope strength shall be at least equivalent to that required of the chain cable.
- (26) Anchors shall be of approved design and shall be manufactured from forged wrought iron, forged open hearth ingot steel or cast steel.
- (27) A test certificate shall be produced to the surveyor for every anchor of more than 75 kg in weight and for every chain cable of 12 mm or more in diameter.

47. Mooring Equipment

Mooring ropes shall be provided in accordance with the table in Annex 2 after determination of the vessels Equipment Number in accordance with regulation 46(18).

CHAPTER IV**STABILITY AND ASSOCIATED SEAWORTHINESS****48. Provision of Stability Information**

- (1) The owner and master of every vessel, to which these Regulations apply, shall cause to be kept on board the ship such information, in writing, about the stability of the ship as is necessary for the guidance of the master in loading and ballasting the vessel.
- (2) The owner of the vessel shall send a copy of the stability information to the Authority for approval prior to the issue of a certificate referred to in regulation 8 of these Regulations..
- (3) The information shall be based upon the determination of the stability of the ship by means of an inclining experiment witnessed by a surveyor from the Authority or person authorised by the Authority.

CHAPTER III

- (4) Any vessel, which is subject to these Regulations, which does not have a stability book, approved by the Authority, on board shall be considered to be unseaworthy and as such the vessels safety certificate, as required by regulation 8 of these Regulations, may be cancelled.

49. Form of Stability Information

- (1) A suitably qualified person recognised by the Authority as competent to provide the required information in a clear and comprehensive manner shall draw up stability information.
- (2) The content of stability books shall be as is laid down in Annex 3.

50. General Intact Stability Criteria

- (1) Vessels shall comply with the following criteria in all operational load conditions:
- (a) The area under the righting lever curve (GZ curve) shall not be less than 0.055 metre radians up to an angle of heel of 30 degrees;
 - (b) The area under the righting lever curve (GZ curve) shall not be less than 0.090 metre radians up to an angle of heel of 40 degrees or the angle of downflooding, if it is less than 40 degrees;
 - (c) The area under the righting lever curve (GZ curve) between the angles of heel of 30 degrees and 40 degrees or 30 degrees and the angle of downflooding, if it is less than 40 degrees, shall not be less than 0.030 metre radians;
 - (d) The righting lever arm (GZ) shall be at least 0.200 metres at an angle of

- heel equal to or greater than 30 degrees.
- (e) The maximum righting arm shall occur at an angle of heel preferably exceeding 30 degrees but not less than 25 degrees; and
- (f) The initial metacentric height (GM_0) shall not be less than 0.350 metres for single-decked vessels. In vessels with complete superstructure or vessels of 70 metres in length or over, the GM_0 may be reduced to the satisfaction

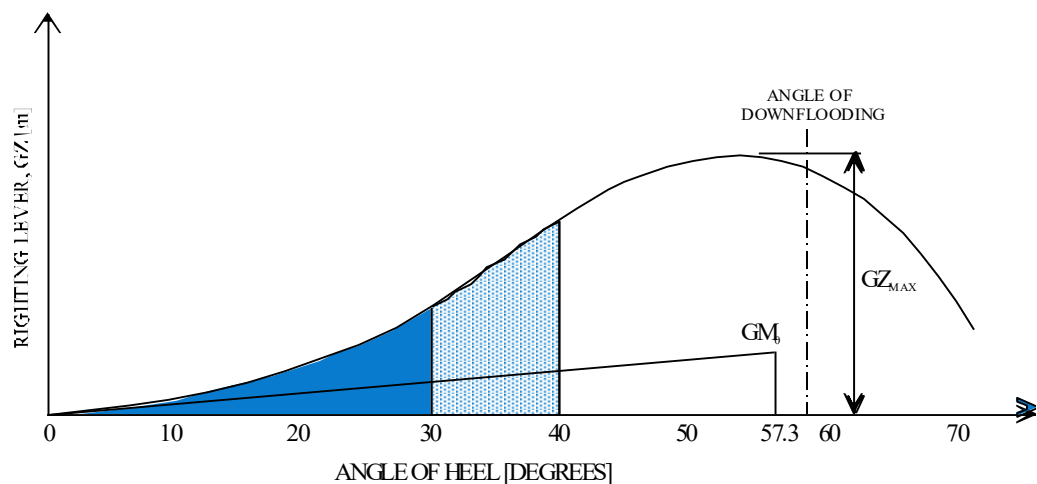

of the Authority but in no case to less than 0.150 metres.

Figure 1 - Fishing Vessel General Intact Stability Criteria

51. Loading Conditions

- (1) The following operational load conditions shall be evaluated:
- (a) Lightship (Non-operational condition);

- (b) Departure from port - the vessel being assumed to be loaded with the necessary equipment, materials and supplies, including ice, fuel, stores, water and nets;
- (c) Arrival at fishing grounds or First fish on board the same as for departure but account being taken of the consumption of fuel, water and stores;
- (d) Departure from fishing grounds the vessel, assumed to be loaded with a 100% catch, but account being taken of the consumption of fuel water and stores;
- (e) Arrival at port with a 100% catch, but 10% fuel, water and stores;
- (f) Arrival at port with a 20% catch, but 10% fuel, water and stores;
- (g) Dry docking condition (Non-operational condition); and
- (h) Worst case load condition – Any operational condition identified which results in a worse stability condition than those described above shall also be investigated. The Authority may define additional load conditions requiring investigation.

52. Lightship

- (1) The vessel lightship condition is not considered to be an operational condition however, the vessel shall have an initial transverse metacentric height (GM_0) of at least 0.05 metres in this condition.
- (2) If the vessel does not meet these criteria, a minimum load condition shall be specified so that this criterion is satisfied.

53. Dry Docking Condition

For the drydocking condition, a condition shall be specified which ensures that the vessel is upright and that the initial transverse metacentric height, GM_0 , remains positive throughout the critical period.

54. Anti-Rolling or Stabilisation Devices

When anti-rolling or stabilisation devices are installed, all stability criteria applicable to the vessel shall be satisfied with the devices in operation and with the devices not in operation.

55. Severe Wind and Rolling

Vessels shall be able to withstand the effects of severe wind and rolling in accordance with the criteria laid down in Annex 5 in all operational load

conditions.

56. Icing Considerations

For vessels operating in areas where ice accretion is likely to occur, as defined in Annex 6 of the Regulations, icing allowances shall be included in the relevant loading conditions in accordance with Annex 6.

57. Lifting of Weights

Vessels engaged in particular fishing methods involving the lifting of heavy weights over the side shall be evaluated in accordance with criteria laid down in Annex 7 in the relevant loading conditions.

58. Fixed Ballast

- (1) Fixed ballast shall be installed under the supervision of the Authority in a manner that prevents any shifting of position of the ballast.
- (2) Fixed ballast shall not be removed from a vessel or relocated within a vessel without the prior approval of the Authority.

59. Form of the Righting Arm (GZ) curve

- (1) Where the righting arm curve has double peaks or the down flooding angle is

excessively large, the GZ curves can be as is shown in figure 2. In these cases the following shall apply:

- (a) The value of maximum GZ shall be taken at the angle of heel corresponding to the first peak or at 50° , whichever angle is less.
- (b) The effective range shall be the angle at which unrestricted downflooding occurs or 70° , whichever angle is less.

Figure 2 – Range and GZ maximum limitations

60. Subdivision and Damaged Stability

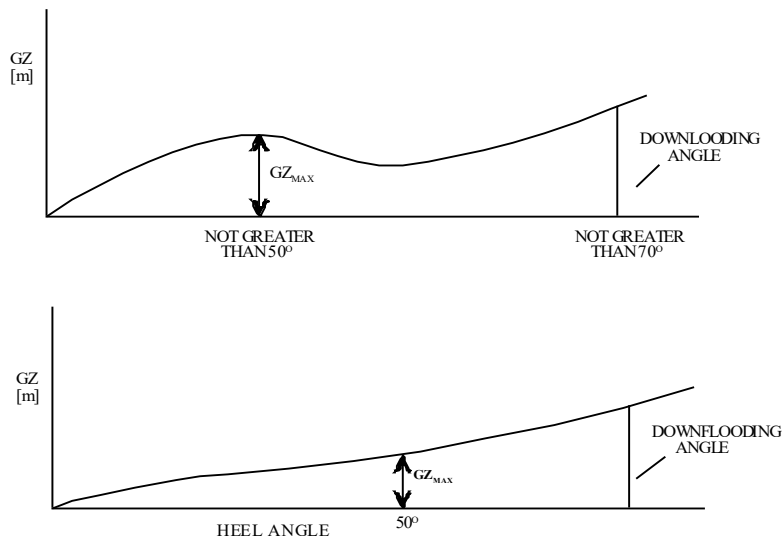

Vessels of 100 metres in length and over, where the total number of persons carried is 100 or more, shall be capable, to the satisfaction of the Authority, of remaining afloat with positive stability, after the flooding of any one compartment assumed damaged.

61. Water on Deck

Except where a vessel has solid bulwarks without openings (excluding freeing ports) greater than $2 \times H_{DA}$, calculated in accordance with Annex 8, above the deepest waterline, it shall be demonstrated that the vessel is able to survive rapid flooding of the well up to the level of the bulwarks. In lieu of such calculations the freeing port area, as required by regulation 45, may be doubled.

62. Flooding of Fish Holds

The heel angle at which progressive flooding of fish holds could occur through hatches which remain open during fishing operations shall be at least 20 degrees unless the stability criteria of regulation 50 can be satisfied with the respective fish holds partially or completely flooded.

63. Portable Fish Hold Divisions

- (1) The catch shall be properly secured against shifting which could cause dangerous trim or heel of the vessel.
- (2) The scantlings of portable fish hold divisions, if fitted, shall be to the satisfaction of the Authority.

64. Bow Height

- (1) The bow height shall be sufficient, to the satisfaction of the Authority to prevent the excessive shipping of water.
- (2) The vessels minimum bow height shall be calculated in accordance with Annex 8.

65. Maximum Permissible Operating Draft

A maximum permissible operating draft shall be assigned by the Authority and shall be calculated in accordance with Annex 8 subject to the vessel complying with the maximum scantling draught and stability criteria of this Chapter.

66. Additional/Alternative Criteria

Where the characteristics of a craft are unsuitable for the application of the criteria presented in these Regulations, the Authority may specify/accept additional or alternative criteria appropriate to the type of craft and area of operation.

67. Sister ships

The Authority shall only accept stability books based on the stability information of a sister ship if the lightship has been proved similar through the conduct of an inclining experiment. ie If a ships lightship displacement is found to be similar to that of a sister ship and the ships intended mode of operation is the same, a copy of the sister ships stability book may be

accepted in lieu of a new stability book being drawn up.

68. Special Cases

If an owner considers that;

- (a) the constancy of a ships voyage conditions,
- (b) her stability characteristics; or
- (c) other circumstances make it unnecessary to provide all the information set forth in this chapter,

He or she shall set forth to the Authority a copy of the information he proposes to provide together with sufficient particulars about the ships service and stability to enable the Authority to decide whether the proposed form of information will be adequate and the Authority may, if satisfied, allow the ship to be provided with the lesser information.

69. Reliability of Information

- (1) A ships stability information shall at all times be reliable and up-to-date.
- (2) If there is any change, for example, in the construction, ballasting or service of the ship which affects the accuracy or adequacy of the stability information, this information shall be properly revised and amended and copies of the amendments shall be sent to the Authority.
- (3) If the change is such as to make the amended information unreliable, the ship shall be re-inclined, and the new information based on the new test shall be

forwarded to the Authority for approval.

- (4) In general, the guidelines illustrated in Annex 9 will be used to determine the requirements for revised stability information.

CHAPTER V

MACHINERY AND ELECTRICAL INSTALLATIONS AND PERIODICALLY UNATTENDED MACHINERY SPACES

PART A - GENERAL

70. Machinery Installations

- (1) Main propulsion, control, steam pipe, fuel oil, compressed air, electrical and refrigeration systems, auxiliary machinery, boilers and other pressure vessels, piping arrangements, steering equipment and gears, shafts and couplings for power transmission shall be designed, constructed, tested, installed and serviced to the satisfaction of the Authority.
- (2) This machinery and equipment, as well as lifting gear, winches, fish handling and fish processing equipment shall be protected so as to reduce to a minimum any danger to persons on board.
- (3) Special attention shall be paid to moving parts, hot surfaces and other dangers.
- (4) Machinery spaces shall be so designed as to provide safe and free access to all machinery and its controls as well as to any other parts which may require servicing.
- (5) Spaces referred to in sub-regulation 4 of this regulation shall be adequately ventilated and lighted to the satisfaction of the Authority.
- (6) (a) Means shall be provided whereby the operational capability of the

propulsion machinery can be sustained or restored even though one of the essential auxiliaries becomes inoperative and special consideration shall be given to the functioning of:

- (i) the arrangements which supply fuel oil pressure for main propulsion machinery;
 - (ii) the normal sources of lubricating oil pressure;
 - (iii) the hydraulic, pneumatic and electrical means for the control of main propulsion machinery including controllable pitch propellers;
 - (iv) the sources of water pressure for main propulsion cooling systems; and
 - (v) an air compressor and an air receiver for starting or control purposes; provided that the Authority may, having regard to overall safety considerations, accept a partial reduction in capability in lieu of full normal operation.
- (b) Means shall be provided whereby the machinery can be brought into operation from the dead ship condition without external aid.
- (7) Main propulsion machinery and all auxiliary machinery essential to the propulsion and safety of the vessel shall, as fitted, be capable of operating whether the vessel is upright or listed up to 15 degrees either way under static conditions and up to 22.5 degrees either way under dynamic conditions, when rolling either way and simultaneously pitching (inclined dynamically) up to 7.5 degrees by bow or stern.
- (8) The Authority may permit deviation from angles referred to in sub-regulation 7 of this regulation, taking into consideration the type, size and service conditions of the vessel.
- (9) Special consideration shall be given to the design, construction and

installation of propulsion machinery systems so that any mode of their vibrations shall not cause undue stresses in such machinery systems in the normal operating ranges.

71. Electrical Installations

The design and construction of electrical installations shall be such as to provide;

- (a) the services necessary to maintain the vessel in normal operational and habitable conditions without having recourse to an emergency source of power;
- (b) the services essential to safety when failure of the main source of electrical power occurs;and
- (c) protection of the crew and vessel from electrical hazards.

72. Periodically Unattended Machinery Spaces

- (1) Regulations 88 to 92 shall apply in addition to regulations 70 to 87, to vessels with periodically unattended machinery spaces.
- (2) Measures shall be taken to the satisfaction of the Authority to ensure that all equipment is functioning in a reliable manner in all operating conditions, including manoeuvring, and that arrangements to the satisfaction of the Authority are made for regular inspections and routine tests to ensure continuous reliable operation.
- (3) Vessels shall be provided with documentary evidence, to the satisfaction of

the Authority, of their fitness to operate with periodically unattended machinery spaces.

PART B - MACHINERY INSTALLATIONS

73. Main and Auxiliary Machinery

- (1) Main and auxiliary machinery, shafting and propeller essential for the propulsion and safety of the vessel shall be of proven commercial marine design and quality and of power suitable for the envisaged application.
- (2) All machinery shall be provided with effective means of control.
- (3) Internal combustion engines with a cylinder diameter greater than 200 millimeters or a crankcase volume greater than 0.6 cubic metres shall be provided with crankcase explosion relief valves of an approved type with sufficient relief area.
- (4) Where main or auxiliary machinery including pressure vessels or any parts of such machinery are subject to internal pressure and may be subject to dangerous over pressure, means shall be provided, where applicable, which will protect against such excessive pressure.
- (5) All gearing and every shaft and coupling used for transmission of power to machinery essential for the propulsion and safety of the vessel or the safety of persons on board shall be so designed and constructed that it will withstand the maximum working stresses to which it may be subjected in all service conditions.
- (6) Due consideration shall be given to the type of engines by which it is driven or of which it forms part.
- (7) Main propulsion machinery and, where applicable, auxiliary machinery shall be provided with automatic shut-off arrangements in the case of failures, such

as lubricating oil supply failure, which could lead rapidly to damage, complete breakdown or explosion.

- (8) An advance alarm shall also be provided so that warning is given before automatic shut-off but the Authority may permit provisions for overriding automatic shut-off devices.
- (9) The Authority may also exempt vessels from the provisions of this regulation, giving consideration to the type of vessel or its specific service.

74. Main Engine Starting Arrangements

- (1) Where main engines depend upon air starting arrangements:
- (a) a minimum of two air receivers shall be provided which are capable of withstanding the pressure assigned to them;
 - (b) The combined capacity of the air receivers shall be sufficient to provide the main engine with 12 consecutive starts if it is a reversible engine or 6 consecutive starts if it is a non-reversible engine, without replenishing the air in the receivers;
 - (c) each air receiver, or the piping between each air compressor and each receiver shall be provided with a safety valve set to operate at or below the assigned working pressure; and
 - (d) one air compressor, driven by a prime mover which can be started without the use of compressed air shall be fitted.
- (2) Where main engines depend upon electrical starting arrangements:
- (a) batteries shall be in duplicate and shall be connected to the starter motor via a change-over switch so that either battery can be used for starting the engine. In normal conditions it shall not be possible to run both batteries in parallel;and
 - (b) the combined capacity of the batteries provided for main engine

starting shall be sufficient to ensure at least 6 consecutive starts of the engine without re-charging.

- (3) Where main engines depend upon means other than those mentioned in paragraphs (a) and (b) of subregulation (2) above, for starting; the Authority shall be satisfied that such means are acceptable for all foreseeable circumstances.

75. Means of Going Astern

- (1) Vessels shall have sufficient power for going astern to secure proper control of the vessel in all normal circumstances.
- (2) The ability of the machinery to reverse the direction of thrust of the propeller in sufficient time and so to bring the vessel to rest within a reasonable distance from maximum ahead service speed shall be to the satisfaction of the Authority.

76. Steam Boilers, Feed Systems and Steam Piping Arrangements

- (1) The Authority shall give special consideration to steam boiler installations to ensure that feed systems, monitoring devices and safety provisions are adequate in all respects to ensure the safety of boilers, steam pressure vessels and steam piping arrangements.
- (2) Every oil-fired steam boiler which is intended to operate without manual supervision shall have safety arrangements which shut off the fuel supply and give an alarm in the case of low water level, air supply failure or flame failure.
- (3) Every steam boiler and every unfired steam generator shall be provided with not less than two safety valves of adequate capacity. Provided that the Authority may, having regard to the output or any other features of any steam boiler or unfired steam generator, permit only one safety valve to be fitted if

satisfied that adequate protection against over pressure is thereby provided.

- (4) Every vessel propelled by steam shall be provided with not less than two entirely separate power feed pumps.
- (5) One of the feed pumps referred to in sub-regulation 4 of this regulation may be operated from the main engines, and the other shall be an independent power pump.
- (6) Safety valves of every new boiler shall, after it has been set to the assigned pressure, be subjected to an accumulation test as follows:
 - (a) **Cylinder Boilers** during a test of 15 minutes with the stop valves closed and under full firing conditions the accumulation of pressure shall not exceed 3 per cent of the working pressure, and during the test no more feed water shall be supplied than is necessary to maintain a safe working water level.
 - (b) **Water Tube Boilers** during a test with the stop valve closed and under full firing conditions, for as long a time as the water supply in the boiler permits; the accumulation of pressure shall not exceed 3 per cent of the working pressure, but in no case need the test exceed seven minutes.
- (7) Boilers shall be hydraulically tested in accordance with the following pressures:
 - (a) For new boilers -
test pressure = $1.25 \times \text{W.P.} + 3.5 \text{ kg/cm}^2$ for W.P.s in excess of 7.5 kg/cm^2
and = $2 \times \text{W.P.}$ for W.P.s of 7.5 kg/cm^2 or less.
 - (b) for existing boilers -
test pressure = $1.25 \times \text{W.P.}$
- (8) When the survey of a new boiler is completed, it shall, in a position which will

be clearly visible at all times, be stamped as follows:

W.P. kg/cm²
 Tested to kg/cm²
 Date

Stamp of Testing Authority

- (9) Pressure parts, other than boilers, when new shall be hydraulically tested in accordance with the following pressures:
- (a) Boiler mountings:
- | | | |
|-------|-------------------|-----------|
| (i) | Feed check valves | 2½ x W.P. |
| (ii) | Other mountings | 2 x W.P. |
| (iii) | Steam pipes | 2 x W.P. |
| (iv) | Feed pipes | 2½ x W.P. |
| (v) | Feed heaters | 2½ x W.P. |
- (bodies, tubes or coils)
- (b) Oil fuel pipes, heaters, coils or tubes: 30 kg/cm² or twice the maximum working pressure to which they are subjected, whichever is greater.
- (c) Evaporator bodies: Twice the maximum working pressure of the evaporator.
- (d) Evaporator coils or tubes: Twice the maximum working pressure to which they may be subjected.
- (e) Air receivers: As for boilers.
- (10) The work required by sub-regulations (6) to (9) of this regulation shall be carried out by a competent person approved by the Authority.

77. Communication between the Wheelhouse and Machinery Space

Two separate means of communication between the wheelhouse and the machinery space control platform shall be provided, one of which shall be an engine room telegraph.

78. Wheelhouse Control of Propulsion Machinery

- (1) Where remote control of propulsion machinery is provided from the wheelhouse, the following shall apply;
 - (a) under all operating conditions, including manoeuvring, the speed, direction of thrust and, if applicable, the pitch of the propeller shall be fully controllable from the wheelhouse;
 - (b) the remote control referred to in paragraph (a) of this regulation shall be performed by means of a control device to the satisfaction of the Authority with, where necessary, means of preventing overload of the propulsion machinery;
 - (c) the main propulsion machinery shall be provided with an emergency stopping device in the wheelhouse and independent from the wheelhouse control system referred to in paragraph (a) of this regulation;
 - (d) remote control of the propulsion machinery shall be possible only from one station at a time: at any control station interlocked control units may be permitted;
 - (e) There shall be at each station an indicator showing which station is in control of the propulsion machinery;
 - (f) The transfer of control between the wheelhouse and machinery spaces

- shall be possible only in the machinery space or control room;
- (g) indicators shall be fitted in the wheelhouse for:
 - (i) propeller speed and direction in the case of fixed propellers;
 - (ii) propeller speed and pitch position in the case of controllable pitch propellers; and
 - (iii) advance alarm as required in regulation 73(8);
 - (h) it shall be possible to control the propulsion machinery locally, even in the case of failure in any part of the remote control system;
 - (i) unless the Authority considers it impracticable the design of the remote control system shall be such that if it fails an alarm will be given and the pre-set speed and direction of thrust will be maintained until local control is in operation;
 - (j) special arrangements shall be provided to ensure that automatic starting shall not exhaust the starting possibilities;and
 - (k) An alarm shall be provided to indicate low starting air pressure and shall be set at a level which will still permit main engine starting operations.
- (2) Where the main propulsion and associated machinery including sources of main electrical supply are provided with various degrees of automatic or remote control and are under continuous manned supervision from a control room, the control room shall be so designed, equipped and installed that the machinery operation will be as safe and effective as if it were under direct supervision.
- (3) In general, automatic starting, operational and control systems shall include means for manually overriding the automatic means, even in the case of

failure of any part of the automatic and remote control system.

79. Air Pressure Systems

- (1) Air receivers and other pressure vessels shall be capable of withstanding the pressure assigned to them.
- (2) Means shall be provided to prevent excess pressure in any part of compressed air systems and wherever water-jackets or casings of air compressors and coolers might be subjected to dangerous excess pressure due to leakage into them from air pressure parts.
- (3) Suitable pressure-relief arrangements shall be provided.
- (4) The main starting air arrangements for main propulsion internal combustion engines shall be adequately protected against the effects of backfiring and internal explosion in the starting air pipes.
- (5) All discharge pipes from starting air compressors shall lead directly to the starting air receivers and all starting pipes from the air receivers to main or auxiliary engines shall be entirely separate from the compressor discharge pipe system.
- (6) Provision shall be made to reduce to a minimum the entry of oil into the air pressure systems and to drain these systems.

80. Arrangements for Fuel Oil, Lubricating Oil and Other Flammable Oils

- (1) Fuel oil which has a flashpoint of less than 60 degrees Celsius (closed cup test) as determined by an approved flashpoint apparatus shall not be used as fuel, except in emergency generators, in which case the flashpoint shall be

not less than 43 degrees Celsius.

Provided that the Authority may permit the general use of fuel oil having a flashpoint of not less than 43 degrees Celsius subject to such additional precautions as it may consider necessary and on condition that the temperature of the space in which such fuel is stored or used shall not rise to within 10 degrees Celsius below the flashpoint of the fuel.

- (2) Safe and efficient means of ascertaining the amount of fuel oil contained in any oil tank shall be provided.
- (3) If sounding pipes are installed, their upper ends shall terminate in safe positions and shall be fitted with suitable means of watertight closure.
- (4) Other means of ascertaining the amount of fuel oil contained in any fuel oil tank may be permitted providing their failure or overfilling of the tanks will not permit release of fuel.
- (5) Gauges made of glass of substantial thickness and protected by metal case may be used, provided that automatic closing valves are fitted.
- (6) Provision shall be made to prevent over pressure in any oil tank or in any part of the fuel oil system including the filling pipes. Relief valves and air or overflow pipes shall discharge to a position and in a manner which is safe.
- (7) Subject to the satisfaction of the Authority, fuel oil pipes which, if damaged, would allow oil to escape from a storage, settling or daily service tank situated above the double bottom, shall be fitted with a cock or valve on the tank capable of being closed from a safe position outside the space concerned in the event of a fire arising in the space in which such tanks are situated.
- (8) In the special case of deep tanks situated in any shaft or pipe tunnel or similar space, valves on the tank shall be fitted but control in the event of fire may be effected by means of an additional valve on the pipe or pipes outside the tunnel or similar space.
- (9) If such additional valve is fitted in the machinery space it shall be capable of

being operated outside this space.

- (10) Pumps forming part of the fuel oil system shall be separate from any other system and the connections of any such pumps shall be provided with an efficient relief valve which shall be in closed circuit.
- (11) Where fuel oil tanks are alternatively used as liquid ballast tanks, proper means shall be provided to isolate the fuel oil and ballast systems.
- (12) No oil tanks shall be situated where spillage or leakage therefrom can constitute a hazard by falling on heated surfaces. Precautions shall be taken to prevent any oil that may escape under pressure from any pump, filter or heater from coming into contact with heated surfaces.
- (13)
 - (a) Fuel oil pipes and their valves and fittings shall be of steel or other equivalent material, provided that restricted use of flexible pipes may be permitted in positions where the Authority is satisfied that they are necessary. Such flexible pipes and end attachments shall be of adequate strength and shall, to the satisfaction of the Authority, be constructed of approved fire-resistant materials or have fire-resistant coatings.
 - (b) Where necessary, fuel oil and lubricating oil pipelines shall be screened or otherwise suitably protected to avoid, as far as practicable, oil spray or oil leakage onto heated surfaces or into machinery air intakes.
 - (c) The number of joints in piping systems shall be kept to a minimum.
- (14) As far as practicable, fuel oil tanks shall be part of the vessel's structure and shall be located outside machinery spaces of Category A.
- (15) Where fuel oil tanks, other than double bottom tanks, are necessarily located adjacent to or within machinery spaces of Category A, at least one of their vertical sides shall be contiguous to the machinery space boundaries, and shall preferably have a common boundary with the double bottom tanks where fitted and the area of the tank boundary common with the machinery

space shall be kept to a minimum.

- (16) When such tanks are sited within the boundaries of machinery spaces of Category A they shall not contain fuel oil having a flashpoint of less than 60 degrees Celsius (closed cup test).
- (17) In general, the use of free-standing fuel oil tanks shall be avoided in fire hazard areas, and particularly in machinery spaces of Category A.
- (18) When free-standing fuel oil tanks are permitted, they shall be placed in an oil-tight spill tray of ample size having a suitable drain pipe leading to a suitably sized spill oil tank.
- (19) The arrangements for the storage, distribution and use of oil employed in pressure lubrication systems shall be to the satisfaction of the Authority. Such arrangements in machinery spaces of Category A and, wherever practicable, in other machinery spaces shall at least comply with the provisions of sub-regulations (1), (6), (12) and (13) and in so far as the Authority may consider necessary with sub-regulations (2), (3), (4), (5), (7), (8) and (9). This does not preclude the use of sight flow glasses in lubrication systems provided they are shown by test to have a suitable degree of fire resistance.
- (20) The arrangements for the storage, distribution and use of flammable oils employed under pressure in power transmission systems other than oils referred to in sub-regulation (10) in control and activating systems and heating systems shall be to the satisfaction of the Authority.
- (21) In location where means of ignition are present such arrangements shall at least comply with the provisions of sub-regulations (2), (3), (4), (5) and (12) and with the provisions of sub-regulations (3) and (13) in respect of strength and construction.

81. Bilge Pumping Arrangements

- (1) An efficient bilge pumping plant shall be provided which under all practical conditions shall be capable of pumping from and draining any watertight compartment which is neither a permanent oil tank nor a permanent water tank whether the vessel is upright or listed.
- (2) Wing suction shall be provided if necessary for the purposes referred to in sub-regulation (1) of this regulation. Arrangements shall be provided for easy flow of water to the suction pipes. (3) Provided the Authority is satisfied that the safety of the vessel is not impaired the bilge pumping arrangements may be dispensed with in particular compartments.
- (4) (a) At least two independently driven power bilge pumps shall be provided, one of which may be driven by the main engine. A ballast pump or other general service pump of sufficient capacity may be used as a power driven bilge pump;
- (b) Power bilge pumps shall be capable of giving a speed of water of at least 2 metres per second through the main bilge pipe which shall have an internal diameter of at least:
- (Main Bilge line) $d = 25 + 1.68 \sqrt{L(B + D)}$ [mm]
- where: d is the internal diameter in millimetres, and L , B and D are in metres;
- (c) Branch bilge lines shall have an internal diameter of at least:
- (Branch bilge line) $d = 25 + 1.68 \sqrt{\sqrt{L}(B + D)}$ [mm]
- where: d is the internal diameter in millimetres, and $\sqrt{}$ (compartment length), B and D are in metres;
- (d) Each of the bilge pumps provided in accordance with this regulation shall be provided with a direct bilge suction, one of these suction

drawing from the port side of the machinery space and the other from the starboard side;

- (e) Notwithstanding the requirements of paragraphs (b) and (c) of this regulation, bilge suctions shall have a minimum inside diameter of 50 millimetres;and
- (f) The arrangement and sizing of the bilge system shall be such that the full rated capacity of the pump specified above can be applied to each of the watertight compartments located between the collision and afterpeak bulkheads.

- (5) A bilge ejector in combination with an independently driven high pressure sea-water pump may be installed as a substitute for one independently driven bilge pump required by sub-regulation (4)(a) of this regulation, provided this arrangement is to the satisfaction of the Authority.
- (6) In vessels where fish handling or processing may cause quantities of water to accumulate in enclosed spaces, adequate drainage, to the satisfaction of the Authority, shall be provided.
- (7) Bilge pipes shall not be led through fuel oil, ballast or double bottom tanks, unless these pipes are of heavy gauge steel construction.
- (8) Bilge and ballast pumping systems shall be arranged so as to prevent water passing from the sea or from water ballast spaces into holds or into machinery spaces or from one watertight compartment to another.
- (9) The bilge connection to any pump which draws from the sea or from water ballast spaces shall be fitted with either a non-return valve or a cock which cannot be opened simultaneously either to the bilges and the sea or to the bilges and water ballast spaces. Valves in bilge distribution boxes shall be of a non-return type or no return valves are to be fitted in the line.
- (10) Any bilge pipe piercing a collision bulkhead shall be fitted with a positive means of closing at the bulkhead with remote control from the working deck with an indicator showing the position of the valve provided that, if the valve is fitted on the after side of the bulkhead and is readily accessible under all service conditions, the remote control may be dispensed with.
- (11) Bilge suction shall generally be fitted with strainers, and the areas of openings of such strainers shall not be less than twice the cross-sectional area of the bilge pipe. Direct emergency bilge suction shall not be fitted with strainers.
- (12) Bilge piping shall be of seamless Schedule 40 steel pipe or other material

considered by the surveyor to be suitable for the purpose, but short lengths of rubber or plastic hose, clearly visible at all times, may be fitted to the satisfaction of the surveyor to reduce the effects of vibration; any hose so installed shall be of sufficient strength to withstand collapsing due to suction, and joints shall be made with clamps suitable for the purpose.

- (13) Bilges in machinery spaces of category A shall be provided with a high level alarm in such a way that the accumulation of liquids is detected at normal angles of trim and heel. The detection system shall initiate an audible and visual alarm in at least one place where continuous watch is maintained.

82. Steering Gear

- (1) Vessels shall be provided with a main steering gear and an auxiliary means of actuating the rudder to the satisfaction of the Authority.
- (2) The main steering gear and the auxiliary means of actuating the rudder shall be arranged so that so far as is reasonable and practicable a single failure in one of them will not render the other one inoperative.
- (3) Where the main steering gear comprises two or more identical power units an auxiliary steering gear need not be fitted if the main steering gear is capable of operating the rudder as required by sub-regulations (15) and (16) of this regulation when any one of the units is out of operation. Each of the power units shall be operated from a separate circuit.
- (4) The position of the rudder, if power operated, shall be indicated in the wheelhouse. The rudder angle indication for power-operated steering gear shall be independent of the steering gear control system.
- (5) In the event of failure of any of the steering gear units an alarm shall be given

in the wheelhouse.

- (6) Indicators for running indication of the motors of electric and electro-hydraulic steering gear shall be installed in the wheelhouse. Short circuit protection, an overload alarm and a no-voltage alarm shall be provided for these circuits and motors.
- (7) Protection against excess current, if provided, shall be not less than twice the full load current of the motor or circuit so protected, and shall be arranged to permit the passage of the appropriate starting currents.
- (8) The main steering gear shall be of adequate strength and sufficient to steer the vessel at maximum service speed.
- (9) The main steering gear and rudder stock shall be so designed that they will not be damaged at maximum speed astern or by manoeuvring during fishing operations.
- (10) The main steering gear shall, with the vessel at its maximum permissible operating draught, be capable of putting the rudder over from 35 degrees on one side to 35 degrees on the other side with the vessel running ahead at maximum service speed.
- (11) The rudder shall be capable of being put over from 35 degrees on either side to 30 degrees on the other side in not more than 28 seconds, under the same conditions.
- (12) The main steering gear shall be operated by power where necessary to fulfil these requirements.
- (13) The main steering gear power unit shall be arranged to start either by manual means in the wheelhouse or automatically when power is restored after a power failure.
- (14) The auxiliary means for actuating the rudder shall be of adequate strength and sufficient to steer the vessel at navigable speed and capable of being

brought speedily into action in an emergency.

- (15) The auxiliary means for actuating the rudder shall be capable of putting the rudder over from 15 degrees on one side to 15 degrees on the other side in not more than 60 seconds with the vessel running at one half of its maximum service speed ahead or 7 knots whichever is the greater.
- (16) The auxiliary means for actuating the rudder shall be operated by power where necessary to fulfill these requirements.
- (17) Electric or electro-hydraulic steering gear in vessels of 75 metres in length and over shall be served by at least two circuits fed from the main switchboard and these circuits shall be as widely separated as possible.

83. Engineers' Alarm

In vessels of 75 metres in length and over an engineers' alarm shall be provided to be operated from the engine control room or at the manoeuvring platform as appropriate, and shall be clearly audible in the engineers accommodation.

84. Refrigeration Systems for Preservation of the Catch

- (1) Refrigeration systems shall be so designed, constructed, tested and installed as to take account of the safety of the systems considering the degree of possible harm to persons or to the environment, and shall be to the satisfaction of the Authority.
- (2) Refrigerants to be used in refrigeration systems shall be to the satisfaction of

the Authority. However, methyl chloride, ammonia or CFC's whose ozone depleting potential is higher than 5% of CFC-11 shall not be used as a refrigerant.

- (3) (a) Refrigerating installations shall be adequately protected against vibration, shock, expansion, shrinkage, etc. and shall be provided with an automatic safety control device to prevent a dangerous rise in temperature and pressure;
- (b) Refrigeration systems in which toxic or flammable refrigerants are used shall be provided with drainage devices leading to a place where the refrigerant presents no danger to the vessels or to persons on board;
- (c) Any space containing refrigerating machinery including condensers and gas tanks utilizing toxic refrigerants shall be separated from any adjacent space by gastight bulkheads;
- (d) Any space containing the refrigerating machinery including condensers and gas tanks shall be fitted with a leak detection system having an indicator outside the space adjacent to the entrance and shall be provided with an independent ventilation system and a water spray system;
- (e) The ventilation ducting to such spaces shall be fitted with a power exhaust fan and shall not be higher than 30 centimetres from the deck or lowest part of the space;and
- (f) When such containment is not practicable, due to the size of the vessel, the refrigeration system may be installed in the machinery space provided that the quantity of refrigerant used will not cause danger to persons in the machinery space, should all the gas escape, and provided that an alarm is fitted to give warning of a dangerous concentration of gas should any leakage occur in the compartment. In such cases there shall be at least three powered ventilation fans installed with at least one being a suction fan with the ducting located

close or at the areas where the refrigerant is potentially exposed to leaks.

- (4) In refrigerating machinery spaces and refrigerating rooms, alarms shall be connected to the wheelhouse or control stations or escape exits to prevent persons being trapped.
- (5) At least one exit from each such space shall be capable of being opened from the inside. Where practicable, exits from the spaces containing refrigerating machinery using toxic or flammable gas shall not lead directly into any accommodation spaces.
- (6) Where any refrigerant harmful to persons is used in a refrigeration system, at least two sets of breathing apparatus shall be provided, one of which shall be placed in a position not likely to become inaccessible in the event of leakage of refrigerant.
- (7) Breathing apparatus provided as part of the vessel's fire-fighting equipment may be considered as meeting all or part of this provision provided its location meets both purposes.
- (8) Where self-contained breathing apparatus is used, spare cylinders shall be provided.
- (9) Adequate guidance for the safe operation and emergency procedures for the refrigeration systems shall be provided by suitable notices displayed on board the vessel.

85. Ventilation

- (1) Ventilation systems serving machinery spaces of category A shall be

independent of systems serving other spaces.

- (2) Ventilation provided in machinery spaces shall be sufficient for engine combustion, the removal of heat and prevention of the accumulation of oil vapours under normal operating conditions and shall be to the satisfaction of the surveyor.
- (3) Compartments which the crew are required to enter as part of their work which may contain gases which are heavier than air e.g. fuel or refrigerant vapour, shall be provided with exhaust fans which take suction from a low position in the compartment to the satisfaction of the surveyor.

PART C - ELECTRICAL INSTALLATIONS

86. Main Source of Electrical Power

- (1) (a) Where electrical power constitutes the only means of maintaining auxiliary services essential for the propulsion and the safety of the vessel, a main source of electrical power shall be provided which shall include at least two generating sets, one of which may be driven by the main engine. The Authority may accept other arrangements having equivalent electrical capability;
- (b) The power of these sets shall be such to ensure the functioning of the services referred to in regulation 71(1), excluding the power required in fishing activities, processing and preservation of the catch, in the event of one of these generators being stopped. However, in vessels of less than 45 metres in length, in the event of any one of the generating sets being stopped, it shall only be necessary to ensure the functioning of services essential for propulsion and safety of the vessel;

- (c) The arrangement of the vessel's main source of electrical power shall be such that the services referred to in regulation 72(1) can be maintained regardless of the number of revolutions and direction of the main propelling engines or shafting; and
 - (d) Where transformers constitute an essential part of the supply system required by this paragraph, the system shall be so arranged as to ensure continuity of the supply.
- (2)
- (a) The arrangement of the main lighting system shall be such that a fire or other casualty in the space or spaces containing the main source of electrical power, including transformers, if any, will not render the emergency lighting system inoperative; and
 - (b) The arrangement of the emergency lighting system shall be such that a fire or other casualty in the space or spaces containing the emergency source of electrical power, including transformers, if any, will not render the main lighting system inoperative.

87. Emergency Source of Electrical Power

- (1) A self-contained emergency source of electrical power located, to the satisfaction of the Authority, outside the machinery spaces shall be provided and so arranged as to ensure its functioning in the event of fire or other causes of failure of the main electrical installations.
- (2) The emergency source of electrical power shall be capable, having regard to starting current and the transitory nature of certain loads, of serving simultaneously for a period of at least three hours:
 - (a) internal communication equipment, fire detecting systems and signals which may be required in an emergency;

- (b) the navigation lights (if solely electrical) and the emergency lights:
 - (i) of launching stations and overside of the vessel;
 - (ii) in all alleyways, stairways and exits;
 - (iii) in spaces containing machinery or the emergency source of power;
 - (iv) in control stations; and
 - (v) in fish handling and fish processing spaces; and
 - (c) The operation of the emergency fire pump, if any.
- (3) The emergency source of electrical power may be either a generator or an accumulator battery:
- (a) batteries required for communications shall not be located below the waterline of the vessel when in a fully loaded condition;
 - (b) batteries required for communications shall be isolated from the vessel's lighting and general service requirements; and
 - (c) the batteries to supply the Radio Installations should comply with the Merchant Shipping Radio Installations Regulations (2002) as amended.
- (4)
- (a) Where the emergency source of electrical power is a generator, it shall be provided both with an independent fuel supply and with efficient starting arrangements to the satisfaction of the Authority;
 - (b) Unless a second independent means of starting the emergency generator is provided the single source of stored energy shall be protected to preclude its complete depletion by the automatic starting system;
 - (c) Where the emergency source of electrical power is an accumulator battery it shall be capable of carrying the emergency load without recharging whilst maintaining the voltage of the battery throughout the discharge period within plus or minus 12 per cent of its nominal

voltage.

- (d) In the event of failure of the main power supply this accumulator battery shall be automatically connected to the emergency switchboard and shall immediately supply at least those services specified in paragraph 2(b) and (c); and
 - (e) The emergency switchboard shall be provided with an auxiliary switch allowing the battery to be connected manually, in case of failure of the automatic connection system.
- (3) The emergency switchboard shall be installed as near as is practicable to the emergency source of power and shall be located in accordance with subregulation (1) of this regulation.
 - (4) Where the emergency source of power is a generator, the emergency switchboard shall be located in the same place unless the operation of the emergency switchboard would thereby be impaired.
 - (5) An accumulator battery fitted in accordance with this Regulation, shall be installed in a well ventilated space which shall not be the space containing the emergency switchboard.
 - (6) An indicator shall be mounted in a suitable place on the main switchboard or in the machinery control room to indicate when the battery constituting the emergency source of power is being discharged.
 - (7) The emergency switchboard is to be supplied in normal operation from the main switchboard by an inter-connector feeder which is to be protected at the main switchboard against overload and short circuit.
 - (8) The arrangement at the emergency switchboard shall be such that in the event of a failure of the main power supply an automatic connection of the emergency supply shall be provided.
 - (9) When the system is arranged for feedback operation, the inter-connector feeder shall also be protected at the emergency switchboard at least against

short circuit.

- (10) The emergency generator and its prime mover and any accumulator battery shall be so arranged as to ensure that they will function at full rated power when the vessel is upright and when rolling up to an angle of 22½ degrees either way and simultaneously pitching 10 degrees by bow or stern, or is in any combination of angles within those limits.
- (11) The emergency source of electrical power and automatic starting equipment shall be so constructed and arranged as to enable adequate testing to be carried out by the crew while the vessel is in operating condition.

88. Precautions against Shock, Fire and Other Hazards of Electrical Origin

- (1) (a) Exposed permanently fixed metal parts of electrical machines or equipment which are not intended to be “live”, but which are liable under fault conditions to become “live” shall be earthed (grounded) unless:
 - (i) they are supplied at a voltage not exceeding 55 volts direct current or 55 volts, root mean square, between conductors; auto transformers shall not be used for the purpose of achieving this alternative current voltage;
 - (ii) they are supplied at a voltage not exceeding 250 volts by safety isolating transformers supplying one consuming device only; or,
 - (iii) they are constructed in accordance with the principle of double insulation.
- (b) Portable electrical equipment shall operate at a safe voltage, exposed metal parts of such equipment which are not intended to have a voltage but which may have such under fault conditions, shall be

- earthed;
- (c) The Authority may require additional precautions for portable electric lamps, tools or similar apparatus for use in confined or exceptionally damp spaces where particular risks due to conductivity may exist; and
 - (d) Electrical apparatus shall be so constructed and so installed that it shall not cause injury when handled or touched in the normal manner.
- (2)
- (a) Main and emergency switchboards shall be so arranged as to give easy access as may be needed to apparatus and equipment, without danger to attendants;
 - (b) The sides and backs and, where necessary, the fronts of switchboards, shall be suitably guarded;
 - (c) Exposed “live” parts having voltages to earth exceeding a voltage to be specified by the Authority shall not be installed on the front of such switchboards;
 - (d) There shall be non-conducting mats or gratings at the front and rear, where necessary;
 - (e) Whilst complying with the requirements of paragraph (a), (b) and (c) of this sub-regulation and the Merchant Shipping Radio Installation Regulations, the radio installation switchboard shall be separate from the main and emergency switchboards to inhibit stray radio frequency and interference;
 - (f) The radio installation switchboard shall not be fitted in the immediate vicinity of the radio battery installation;
 - (g) The radio installation earthed connections and arrangements shall be separately installed and connected by utilizing earth leads of copper foil and not round wires;and
 - (h) In vessels constructed of non-conductive materials, the following two

earth arrangements are acceptable-

- Separate paint-free Dyna Plate type;
- Or alternative methods of earthing integral to the hull maybe accepted by the Authority.

- (3) (a) The hull return system of distribution shall not be used for power, heating or lighting; and
- (b) The requirement of paragraph (a) of this sub-regulation does not preclude, under conditions approved by the Authority, the use of:
- (i) impressed current cathodic protection systems;
 - (ii) limited and locally earthed systems; and
 - (iii) insulation level monitoring devices provided the circulation current does not exceed 30 milli-amperes under the most unfavourable conditions.
- (4) Where a distribution system, whether primary or secondary, for power, heating or lighting, where no connection to earth is used, a device capable of monitoring the insulation level to earth and of giving an audible or visual indication of abnormally low insulation values shall be provided.
- (5) (a) Except as permitted by the Authority in exceptional circumstances, all metal sheaths and armour of cables shall be electrically continuous and shall be earthed;
- (b) All electrical cables shall be at least of a flame retardant type and shall be so installed as not to impair the original flame-retarding properties;
- (c) The Authority may permit the use of special types of cables when necessary for particular applications, such as radio frequency cables, which do not comply with the foregoing;
- (d) Cables and wiring serving essential or emergency power, lighting, internal communications or signals shall as far as practicable be routed clear of galleys, machinery spaces of category A and other high fire

- risk areas and laundries, fish handling and fish processing spaces and other spaces where high moisture level can be expected;
- (e) Cables connecting fire pumps to the emergency switchboard shall be of a fire resistant type where they pass through high fire risk areas;
 - (f) Where practicable all such cables should be run in such a manner as to preclude their being rendered unserviceable by heating of bulkheads that may be caused by a fire in an adjacent space.
 - (g) Where cables which are installed in spaces where the risk of fire or explosion exists in the event of an electrical fault, special precautions against such risks shall be taken to the satisfaction of the Authority;
 - (h) Wiring shall be supported in such a manner as to avoid chaffing or other damage;
 - (i) Terminations and joints in all conductors shall be made such that they retain the original electrical, mechanical, flame-retarding and, where necessary, fire-resisting properties of the cable; and
 - (j) Cables installed in refrigerated compartments shall be suitable for low temperatures and high humidity.
- (6) (a) Circuits shall be protected against short circuit;
- (b) Circuits shall also be protected against overload, except in accordance with regulation 82 or where the Authority may exceptionally otherwise permit; and
- (c) The rating or appropriate setting of the overload protective device for each circuit shall be permanently indicated at the location of the protective device.
- (7) Lighting fittings shall be arranged to prevent temperature rises which could damage the wiring and to prevent surrounding material from becoming excessively hot.
- (8) Lighting or power circuits terminating in a space where the risk of fire or explosion exists shall be provided with isolating switches outside the space.
- (9) (a) The housing of an accumulator battery shall be constructed and

ventilated to the satisfaction of the Authority;

- (b) electrical and other equipment which may constitute a source of ignition of flammable vapours shall not be permitted in these compartments except as permitted in sub-regulation (10) of this regulation; and
- (c) an accumulator battery shall not be located in accommodation spaces unless installed in a hermetically sealed container.

(10) In spaces where flammable mixtures are liable to collect and in any compartment assigned principally to the containment of an accumulator battery, no electrical equipment shall be installed unless the Authority is satisfied that it is:

- (a) essential for operational purposes;
- (b) of a type which will not ignite the mixture concerned;
- (c) appropriate to the space concerned; and
- (d) appropriately certified for safe usage in the dusts, vapours or gases likely to be encountered.

(11) Lightning conductors shall be fitted to all wooden masts or topmasts.

(12) In vessels constructed of non-conductive materials the lightning conductors shall be connected by suitable conductors to a copper plate fixed to the vessel's hull well below the waterline.

PART D - ADDITIONAL REQUIREMENTS FOR PERIODICALLY UNATTENDED MACHINERY SPACES

89. Fire Safety

(1) Fire prevention:

- (a) Special consideration shall be given to high pressure fuel oil pipes;
 - (b) where practicable, leakages from such piping systems shall be collected in a suitable drain tank which shall be provided with a high level alarm;
 - (c) where daily service fuel oil tanks are filled automatically or by remote control, means shall be provided to prevent overflow spillages;
 - (d) similar consideration shall be given to other equipment which treats flammable liquids automatically, e.g. fuel oil purifiers, which whenever practicable shall be installed in a special space reserved for purifiers and their heaters; and
 - (e) Where fuel oil daily service tanks or settling tanks are fitted with heating arrangements, a high temperature alarm shall be provided if the flashpoint of the fuel oil can be exceeded.
- (2) Fire detection:
- (a) an approved fire detection system based on a self-monitoring principle and including facilities for periodical testing shall be installed in machinery spaces;
 - (b) the detection system shall initiate both audible and visual alarm in the wheelhouse and in sufficient appropriate spaces to be heard and observed by persons on board, when the vessel is in harbour;
 - (c) the fire detection system shall be fed automatically from an emergency source of power if the main source of power fails; and
 - (d) internal combustion engines of 2500 kilowatts and over shall be provided with crankcase oil mist detectors or engine bearing temperature detectors or equivalent devices.
- (3) Fire fighting:
- (a) a fixed fire-extinguishing system shall be provided to the satisfaction of the Authority, which shall be in compliance with the requirements of

Chapter VI.

- (b) in vessels of 75 metres and over provision shall be made for immediate water delivery from the fire main system either by:
- (i) remote starting arrangements on one of the main fire pumps in the wheelhouse and at the fire control station, if any; or
 - (ii) permanent pressurization of the fire main system, due regard being paid to the possibility of freezing; and
- (c) the Authority shall be satisfied with the maintenance of the fire integrity of the machinery spaces, the location and centralization of the fire-extinguishing system controls, the shut-down arrangements referred to in regulation 94 e.g. ventilation, fuel pumps, etc., and may require fire-extinguishing appliances and other fire-fighting equipment and breathing apparatus in addition to the relevant requirements of chapter VI.

90. Protection against Flooding

In vessels of 45 metres in length and over the controls of any valve serving a sea inlet, a discharge below the waterline or a bilge injection system shall be so sited as to allow adequate time for operation in case of influx of water to the space.

91. Communications

- (1) One of the two separate means of communication referred to in regulation 76 shall be a reliable voice communication.
- (2) In vessels of 75 metres and over an additional reliable means of vocal communication shall be provided between the wheelhouse and the engineers'

accommodation.

92. Alarm Systems

- (1) An alarm system shall be provided which shall indicate any fault requiring attention.
 - (2)
 - (a) The alarm system shall be capable of sounding an audible alarm in the machinery space and indicate visually each separate alarm function at a suitable position;
 - (b) In vessels of 45 metres in length and over the alarm system shall have a connection to the engineers cabin through a selector switch to ensure connection to one of those cabins and to the engineers' public rooms, if any;
 - (c) the Authority may permit alternative arrangements which permit equivalent safety;
 - (d) in vessels of 45 metres in length and over an engineers' alarm and an alarm in the wheelhouse for persons on watch shall be activated if an alarm function has not received attention within a period of not more than 3 minutes;
 - (e) audible and visual alarms shall be activated in the wheelhouse for any situation requiring action by the responsible person on watch or which should be brought to his attention; and
 - (f) the alarm system shall as far as is practicable be designed on the fail-safe principle.
- (3) The alarm system shall be:
 - (a) continuously powered with automatic change-over to a stand-by power supply in case of loss of normal power supply; and
 - (b) activated by failure of the normal power supply.
 - (4)
 - (a) The alarm system shall be able to indicate at the same time more than

one fault and the acceptance of any alarm shall not inhibit another alarm;

- (b) acceptance at the position referred to in sub-regulation (2)(a) of any alarm condition shall be indicated at the positions where it was shown;
- (c) alarms shall be maintained until they are accepted and the visual indicators shall remain until the fault has been corrected; and
- (d) all alarms shall automatically reset when the fault has been rectified.

93. Special Requirements for Machinery, Boiler and Electrical Installations

- (1) In vessels of 75 metres and over the main source of electrical power shall be supplied as follows:
 - (a) where the electrical power can normally be supplied by one generator, there shall be provided suitable load shedding arrangements to ensure the integrity of supplies to services required for propulsion and steering;
 - (b) to cover the case of loss of the generator in operation, there shall be adequate provisions for automatic steering and connection to the main switchboard of a stand-by generator of sufficient capacity to permit the propulsion and steering and with automatic starting of the essential auxiliaries, including where necessary, sequential operations;
 - (c) resources may be provided, to the satisfaction of the Authority for remote (manual) starting and connection of the stand-by generator to the main switchboard as well as resources of repeated remote starting of the essential generators; and
 - (d) if the electrical power is normally supplied by more than one generating set simultaneously, there shall be provisions, e.g. by load shedding, to ensure that in cases of loss of one of those generating sets, the remaining ones are kept in operation, without overload, to permit

propulsion and steering.

- (2) Where required to be duplicated, auxiliary machinery essential to propulsion shall be fitted with automatic change-over devices allowing transfer to a stand-by machine. An alarm shall be given on automatic change-over.
- (3) Automatic control and alarm systems shall be provided as follows:
 - (a) the control system shall be such that through the necessary automatic arrangements the services needed for the operation of the main propulsion machinery and its auxiliaries are ensured;
 - (b) resources shall be provided to keep the starting air pressure at the required level where internal combustion engines are used for main propulsion;
 - (c) an alarm system complying with regulation 91 shall be provided for all important pressures, temperatures, fluid levels, etc.; and
 - (d) where appropriate an adequate central position shall be arranged with the necessary alarm panels and instrumentation indicating any alarmed fault.

94. Safety System

- (1) A safety system shall be provided so that serious malfunction in machinery or boiler operations, which presents an immediate danger, shall initiate the automatic shut-down of that part of the plant and an alarm shall be given.
- (2) Shut-down of the propulsion system shall not be automatically activated except in cases which could lead to serious damage, complete breakdown, or explosion.
- (3) Where arrangements for overriding the shut-down of the main propelling

machinery are fitted these shall be such as to preclude inadvertent activation.

- (4) Visual means shall be provided to show whether or not it has been activated

CHAPTER VI

FIRE PROTECTION, FIRE DETECTION, FIRE EXTINCTION AND FIRE FIGHTING

PART A - FIRE SAFETY MEASURES FOR VESSELS LESS THAN 60 METRES IN LENGTH

95. Structural Fire Protection

- (1) The hull, Superstructure, structural bulkheads, decks and deckhouses shall be constructed of non-combustible materials.
- (2) The Authority may permit combustible construction provided the requirements of this Regulation and the additional fire-extinguishing requirements of Regulation 108(3) are complied with.
- (3) (a) In vessels, the hull of which is constructed of non-combustible materials, the decks and bulkheads separating machinery spaces of category A from accommodation spaces, service spaces or control spaces shall be constructed to "A-60" Class standard where the machinery space is not provided with a fixed fire-extinguishing system and to "A-30" Class standard where such system is fitted;
- (b) decks and bulkheads separating other machinery spaces from accommodation, service spaces and control stations shall be constructed to "A-0" Class standard;
- (c) decks and bulkheads separating control stations from accommodation

- and service spaces shall be constructed to "A" Class standard, except that the Authority may permit the fitting of "B-15" Class divisions from separating such spaces as the masters cabin from the wheelhouse;
- (d) in vessels, the hull of which is constructed of combustible materials, the decks and bulkheads separating machinery spaces from accommodation spaces, service spaces or control stations shall be constructed to "F" Class or "B-15" Class standard; and
 - (e) in addition, machinery space boundaries shall as far as practicable prevent the passage of smoke. Decks and bulkheads separating control stations from accommodation and service spaces shall be constructed to "F" Class standard.
- (4) (a) In vessels, the hull of which is constructed of non-combustible materials, bulkheads of corridors serving accommodation, service spaces and control stations shall be of "B-15" Class divisions;
- (b) in vessels, the hull of which is constructed of combustible materials, bulkheads of corridors serving accommodation, service spaces and control stations shall be of "F" Class divisions; and
 - (c) any bulkhead required by paragraphs (a) or (b) of this sub-regulation shall extend from deck to deck unless a continuous ceiling as the same class as the bulkhead is fitted on both sides of the bulkhead, in which case the bulkhead may terminate at the continuous ceiling.
- (5) Interior stairways serving accommodation spaces, service spaces or control stations shall be of steel or other equivalent material.
- (6) Stairways referred to in sub-regulation (5) of this regulation shall be within enclosures constructed of "F" Class divisions in vessels the hull of which is constructed of combustible materials, or "B-15" Class divisions in vessels the hull of which is constructed of non-combustible materials, provided that where a stairway penetrates only one deck it may be enclosed at one level only.

- (7) Doors and other closures of openings in bulkheads and decks referred to in sub-regulations (3) and (4) of this regulation, doors fitted to stairway enclosures referred to in sub-regulations(5) and (6) of this regulation and doors fitted in engine and boiler casings, shall be as far as practicable equivalent in resisting fire to the divisions in which they are fitted.
- (8) Doors to machinery spaces of category A shall be self-closing.
- (9) Lift trunks which pass through the accommodation and service spaces shall be constructed of steel or equivalent material and shall be provided with means of closing which will permit control of draught and smoke.
- (10) (a) In vessels, the hull of which is constructed of combustible materials, the boundary bulkheads of decks and spaces containing any emergency source of power and decks and bulkheads between galleys, paint rooms, lamp rooms or any store rooms which contain appreciable quantities of highly flammable materials, and accommodation spaces, service spaces or control stations shall be constructed of "F" Class or "B-15" Class divisions;
- (b) in vessels, the hull of which is constructed of non-combustible materials, the decks and bulkheads referred to in paragraph (a) of this sub-regulation shall be of A Class divisions insulated to the satisfaction of the Authority, having in mind the risk of fire, except that the Authority may accept "B-15" Class divisions between a galley and accommodation spaces, service spaces and control stations when the galley contains electrically heated furnaces, electrically heated hot water appliances or other electrically heated appliances only; and
- (c) highly flammable products shall be carried in suitably sealed containers.
- (11) Where bulkheads or decks required by sub-regulations (3), (4), (7), (8) or (10) of this regulation to be of "A" Class, "B" Class or "F" Class divisions, are penetrated for the passage of electrical cables, pipes, trunks, ducts, etc., arrangements shall be made to ensure that the fire integrity of the division is not impaired.

- (12) Air spaces enclosed behind ceilings, panellings or linings in accommodation spaces, service spaces and control stations, shall be divided by close fitting draught stops fitted not more than 7 metres apart.
- (13) Windows and skylights to machinery spaces shall be as follows:
- (a) where skylights can be opened they shall be capable of being closed from outside the space. Skylights containing glass panels shall be fitted with external shutters of steel or other equivalent material permanently attached;
 - (b) glass or similar materials shall not be fitted in machinery space boundaries. This does not preclude the use of wire-reinforced glass for skylights and glass in control rooms within the machinery spaces; and
 - (c) in skylights referred to in paragraph (a) of this sub-regulation wire-reinforced glass shall be used.
- (14) Insulating materials in accommodation spaces, service spaces except domestic refrigerating compartments, control stations and machinery spaces shall be non-combustible.
- (15) The surface of insulation fitted on the internal boundaries of machinery spaces of category A shall be impervious to oil or oil vapours.
- (16) Within compartments used for the stowage of fish, combustible insulation shall be protected by close-fitting cladding.
- (17) Notwithstanding the requirements of this Regulation, the Authority may accept "A-0" class divisions in lieu of "B-15" or "F" class divisions, having regard to the amount of combustible material used in adjacent spaces.

96. Ventilation Systems

- (1) Except as provided for regulation 97(2), means shall be provided to stop fans and close main openings to ventilation systems from outside the spaces served.

- (2) Resources shall be provided for closing, from a safe position, the annular spaces around funnels.
- (3) Ventilation openings may be permitted in and under the doors in corridor bulkheads except that such openings shall not be permitted in and under stairway enclosure doors.
- (4) The openings shall be provided only in the lower half of the door.
- (5) Where such opening is in or under a door the total nett area of any such opening or openings shall not exceed 0.05 square metres.
- (6) When such opening is cut in a door it shall be fitted with a grill and closing slide made of a non-combustible material.
- (7) Ventilation ducts for machinery spaces of category A or galleys shall not in general pass through accommodation spaces, service spaces or control stations.
- (8) Where the Authority permits this arrangement, the ducts shall be constructed of steel or equivalent material and arranged to preserve the integrity of the divisions.
- (9) Ventilation ducts of accommodation spaces, service spaces or control stations shall not in general pass through machinery spaces of category A or through galleys.
- (10) Where the Authority permits this arrangement, the ducts shall be constructed of steel or equivalent material and arranged to preserve the integrity of the divisions.
- (11) Store rooms containing appreciable quantities of highly flammable products shall be provided with ventilation arrangements which are separate from other ventilation systems.
- (12) Ventilation shall be arranged at high and low levels and inlets and outlets of ventilators shall be positioned in safe areas and fitted with spark arrestors in accordance with Regulation 14(3) of Chapter III.

- (13) Ventilation systems serving machinery spaces shall be independent from systems serving other spaces.
- (14) Where trunks or ducts serve spaces on both sides of "A" Class bulkheads or decks, dampers shall be fitted so as to prevent the spread of fire and smoke between compartments.
- (15) Manual dampers shall be operable from both sides of the bulkhead on deck.
- (16) Where the trunks or ducts with a free cross sectional area of 0.02 square metres or more pass through "A" Class bulkheads or decks, automatic self-closing dampers shall be fitted.
- (17) Trunks serving compartments situated only on one side of the bulkheads shall comply with Regulation 26(2)(b).

97. Heating Installations

- (1) Electric radiators shall be fixed in position and so constructed as to reduce fire risks to a minimum and no such radiator shall be fitted with an element so exposed that clothing, curtains or other similar materials can be scorched or set on fire by heat from the element.
- (2) Heating by means of open fires shall not be permitted and all Heating appliances of any design shall be firmly secured with adequate protection and insulation against the risk of fire.
- (3) Open flame gas appliances, except cooking stoves and water heaters, shall not be permitted.
- (4) Spaces containing any such stove or water heater shall have adequate ventilation supplying combustion air and to remove fumes and possible gas leakage to a safe place.

- (5) All pipes conveying gas from container to such appliance shall be of seamless steel, copper or other approved material.
- (6) An automatic gas shut-off flame failure device shall be fitted on any such appliance.

98. Remote Fuel Stops

- (1) Machinery driving fuel oil transfer pumps, fuel oil unit pumps and other similar fuel pumps shall be fitted with remote controls situated outside the space concerned so that they can be stopped in the event of a fire arising in the space in which they are located.
- (2) Pipes connected to any oil fuel storage, settling, or daily service tank, not being a double bottom tank, which if damaged would permit discharge of the contents, due to the gravitational head, so as to cause a fire hazard, shall be fitted with a valve or cock which shall be secured to the tank to which it is connected and be capable of being closed from a readily accessible position outside the space in which the tank is situated.
- (3) In the case of an oil fuel deep tank traversed by any shaft or pipe tunnel, in addition to the valve which shall be fitted on the tank, a valve or valves may be fitted on the pipe line or lines outside such tunnel to enable safe control to be exercised in the event of fire.

99. Miscellaneous Items

- (1) Exposed surfaces within accommodation spaces, service spaces, control stations, corridor and stairway enclosures and concealed surfaces behind

bulkheads, ceilings, panellings and linings in accommodation spaces, service spaces and control stations shall have low flame-spread characteristics.

- (2) All exposed surfaces of fibre reinforced plastic construction within accommodation and service spaces, control stations, machinery spaces of category
- (3) A and other machinery spaces of equal fire risk shall achieve the required fire resistance through the use of woven roving [more modern glass types!!!] glass, phenolic resin, additives to resin, fire retardent coatings or protection by non-combustible materials.
- (4) Intumescent (*swelling*) polyester resin coatings may be used, however, solvent borne intumescent coatings are not acceptable.
- (5) Paints, varnishes and other finishes used on exposed interior surfaces shall not be capable of producing excessive quantities of smoke or toxic gases or vapours.
- (6) The Authority shall be satisfied that they are not of a nature to offer an undue fire hazard.
- (7) Primary deck coverings within accommodation and service spaces and control stations, shall be of approved material which will not readily ignite or give rise to toxic or explosive hazards at elevated temperatures.
- (8)
 - (a) In accommodation and service spaces and control stations, pipes penetrating "A" or "B" Class divisions shall be of approved materials having regard to the temperature such divisions are required to withstand and here the Authority permits the conveying of oil and combustible liquids through accommodation and service spaces, the pipes conveying oil or combustible liquids shall be of an approved material having regard to the fire risk.
 - (b) Materials readily rendered ineffective by heat shall not be used for overboard scuppers, sanitary discharges, inlets and other outlets which are close to the waterline and where the failure of the material in the

event of fire would give rise to danger of flooding.

- (9) All waste receptacles other than those used in fish processing shall be constructed of non-combustible materials with no openings in the sides or bottom.
- (10) The main and auxiliary diesel engines, of a vessel shall be fitted with suitable silencers.
- (11) The silencers and exhaust pipes shall be efficiently lagged, water-cooled, or installed in such a manner that they will not create a fire risk. Exhaust lagging shall be made from or covered with a non-absorbent material so that it is impervious to oil.
- (12) Every possible precaution shall be taken to avoid fuel and lubricating oil running into the bilges.
- (13) Drip trays with proper means of drainage to a drain tank or save-all shall be provided under fuel tank outlets and, where possible, under engine

100. Storage of Gas Cylinders and Dangerous Materials

- (1) Cylinders for compressed, liquefied or dissolved gases shall be clearly marked by means of prescribed identifying colours, have a clearly legible identification of the name and chemical formula of their contents and be properly secured.
- (2) Cylinders containing flammable or other dangerous gases and empty cylinders shall be stored, properly secured, on open decks and all valves, pressure regulators and pipes leading from such cylinders shall be protected against damage.
- (3) Cylinders shall be protected against excessive variations in temperature

direct rays of the sun, and accumulation of snow. However, the Authority may permit such cylinders to be stored in compartments complying with the requirements of sub-regulations (3) to (5).

- (4) Spaces containing highly flammable liquids, such as volatile paints, paraffin, benzole, etc., and where permitted, liquefied gas, shall have direct access from open decks only. Pressure-adjusting devices and relief valves shall exhaust within the compartment. Where boundary bulkheads of such compartments adjoin other enclosed spaces they shall be gastight. Ventilation of the spaces shall be in accordance with regulation 96(11) and (12).
- (5) Except as necessary for service within the space, electrical wiring and fittings shall not be permitted within compartments used for the storage of highly flammable liquids or liquefied gases.
- (6) Where such electrical fittings are installed, they shall be to the satisfaction of the Authority for use in a flammable atmosphere.
- (7) Sources of heat shall be kept clear of such spaces and "No Smoking" and "No Naked Light" notices shall be displayed in a prominent position.
- (8) Separate storage shall be provided for each type of compressed gas.
- (9) Compartments used for the storage of such gases shall not be used for storage of other combustible products nor for tools or objects not part of the gas distribution system.
- (10) However, the Authority may relax these requirements considering the characteristics. Volume and intended use of such compressed gases.

101. Means of Escape

- (1) Stairways and ladders leading to and from all accommodation spaces and in spaces in which the crew is normally employed, other than machinery spaces,

shall be so arranged as to provide ready means of escape to the open deck and thence to the survival craft. In particular in relation to these spaces:

- (a) at all levels of accommodation at least two widely separate means of escape shall be provided which may include the normal means of access from each restricted space or group of spaces;
 - (b)
 - (i) below the weather deck the main means of escape shall be a stairway and the second escape may be a trunk or a stairway; and,
 - (ii) above the weather deck the means of escape shall be stairways or doors to an open deck or a combination thereof. Where it is not practical to fit stairways or doors, one of these means of escape may be by means of an adequately sized porthole or hatch protected, where necessary, against ice accretion.
 - (c) exceptionally the Authority may permit only one means of escape, due regard being paid to the nature and location of spaces and to the number of persons who normally might be accommodated or employed there. The Authority will only consider reducing the number of escapes in cases where 10 persons or less are accommodated in a space;
 - (d) a corridor or part of a corridor from which there is only one route of escape, shall preferably not exceed 2.5 metres in length and in no case be greater than 5.0 metres in length; and
 - (e) the width and continuity of the means of escape shall be to the satisfaction of the Authority.
- (2) Two means of escape shall be provided from every machinery space of Category A which shall be as widely separated as possible and Vertical escapes shall be by means of steel ladders.

- (3) From machinery spaces other than those of Category A, escape routes shall be provided to the satisfaction of the Authority having regard to the nature and location of the space and whether persons are normally employed in that space.
- (4) Lifts shall not be considered as forming one of the required means of escape.

102. Automatic Alarm and Fire Detection Systems

Where the Authority has permitted under regulation (95) a combustible construction, or where otherwise appreciable amounts of combustible materials are used on the construction of accommodation spaces, service spaces and control stations, an automatic fire alarm and detection system shall be installed in those spaces, having due regard to the size of those spaces, their arrangement and location relative to control stations as well as, where applicable, the flame spread characteristics of the installed furniture. Such installations shall be to the satisfaction of the Authority.

103. Fire Pumps

- (1) The minimum number and type of fire pumps to be fitted shall be as follows:
 - (a) two power pumps not dependent on the main machinery for their motive power; or,
 - (b) one power pump not dependent on the main machinery for its motive power and one power pump which may be driven by main machinery provided that the propeller shafting can be readily disconnected or provided that a controllable pitch propeller is fitted.
- (2) (a) Sanitary, bilge, ballast, general service or any other pumps may be used as fire pumps if they comply with the requirements of this chapter and

do not affect the ability to cope with pumping of the bilges; and

(b) Fire pumps shall be so connected that they cannot be used for pumping oil or other flammable liquids.

- (3) Centrifugal pumps or other pumps connected to the fire main through which backflow could occur shall be fitted with non-return valves.
- (4) The total capacity (Q) of main power-operated fire pumps shall be at least:
$$Q = (0.15 \square L(B + D) + 2.25)^2$$
 cubic metres per hour
where L, B and D are in metres.
- (5) Neither of the power pumps fitted shall have a capacity of less than 40% of Q.
- (6) Where the main fire pumps are delivering the quantity of water required by sub-regulation (4) of this regulation through the fire main, fire hoses and nozzles, the pressure maintained at any hydrant shall not be less than 0.25 Newtons per square millimetre. (0.25 MPa or 2.5 Bar)

104. Fire Mains

- (1) Where more than one hydrant is required to provide the number of jets specified in regulation 105(1) a fire main shall be provided.
- (2) Materials rendered ineffective by heat shall not be used for fire mains, unless adequately protected.
- (3) Where fire pump delivery pressure can exceed the design working pressure of fire mains, relief valves shall be fitted.
- (4) Fire mains shall have no connections other than those required for fire fighting except for the purpose of washing the deck and anchor chains or operating the chain locker bilge ejector, subject to the efficiency of the fire

fighting system being maintained.

- (5) Where fire mains are not self-draining, suitable drain cocks shall be fitted where frost damage may be expected.

105. Fire Hydrants, Fire Hoses and Nozzles

- (1) Fire hydrants shall be positioned so as to allow easy and quick connection of fire hoses and so that at least one jet can be directed into any part of the vessel which is normally accessible during navigation.
- (2) The jet required by sub-regulation (1) of this regulation shall be from a single length of fire hose.
- (3) In addition to the requirements of sub-regulation (1) of this regulation, machinery spaces of category A shall be provided with at least one fire hydrant complete with fire hose and jet or spray nozzle and this fire hydrant shall be located outside the space and near the entrance.
- (4) For every required fire hydrant there shall be one fire hose and at least one spare fire hose shall be required in addition to this requirement.
- (5) Single lengths of hose shall not exceed 20 metres in length.
- (6) Fire hoses shall be of approved material.
- (7) Each fire hose shall be provided with couplings and a dual purpose nozzle.
- (8) Couplings and nozzles shall be securely connected to fire hoses to the satisfaction of the Authority.
- (9) Domestic hose clamps shall not be accepted for this purpose.
- (10) Except where fire hoses are permanently attached to the fire main, there shall

be complete interchangeability of fire hose couplings and nozzles.

- (11) The nozzles required by sub-regulations (7) and (8) of this regulation shall be appropriate to the delivery capacity of the fire pumps fitted, but in any case shall have a diameter of not less than 12 millimetres.

106. Fire Extinguishers

- (1) Fire extinguishers shall be of approved types. Every fire extinguisher provided in compliance with this Chapter shall be constructed in accordance with the specifications published by the National Standards Regulator and the Authority by Marine Notice which may be up-dated from time to time.
- (2) The capacity of required portable fire extinguishers (other than carbon dioxide extinguishers) shall be not more than 13.5 litres and not less than 9 litres.
- (3) Other extinguisher shall not be in excess of the equivalent portability of the 13.5 litre fluid extinguisher and shall not be less than the fire-extinguishing equivalents of a 9 litre fluid extinguisher.
- (4) The Authority shall determine the equivalents of fire extinguishers.
- (5) Fire extinguishers containing an extinguishing medium which in the opinion of the Authority, either by itself or under expected conditions of use, gives off toxic gases in such quantities as to endanger persons shall not be permitted or shall be subject to safety measures as determined by the Authority.

- (6) Normally, one of the portable fire extinguishers intended for use in any space shall be stowed near an entrance to that space.

107. Portable Fire Extinguishers and Fire Blankets in Control Stations and Accommodation and Service Spaces

- (1) A sufficient number of approved portable fire extinguishers shall be provided in control stations and accommodation and service spaces to ensure that at least one extinguisher, of a suitable type, is readily available for use in any part of such spaces.
- (2) The total number of extinguishers in spaces referred to in sub-regulation (1) of this regulation shall however not be less than three in vessels of less than 45 metres in length and five for vessels of 45 metres in length and over.
- (3) Where portable dry powder extinguishers are provided in either accommodation and service spaces or in machinery spaces, the numbers shall not exceed 50% of the total number of extinguishers provided in either of those spaces.
- (4) Every galley is to be provided with a fire blanket which is to be mounted on a bulkhead near an access doorway in a position allowing easy retrieval.

108. Fire-Extinguishing Appliances in Machinery Spaces

- (1) Spaces containing oil fired boiler units, fuel oil units or internal combustion machinery used either for main propulsion or for other purposes having a total power output of not less than 375 kilowatts, shall be provided with one of the

following fixed fire extinguishing systems to the satisfaction of the Authority:

- (a) a pressure water spraying installation;
- (b) a fire smothering gas installation;
- (c) a fire extinguishing installation using high expansion foam; or
- (d) a fire extinguishing installation using vapours from low toxicity vapourising liquids.

(2) Installations referred to in sub-regulation (1) of this regulation shall be controlled from readily accessible positions outside the machinery space not likely to be inaccessible by a fire in such space or any other space.

(3) The installation shall be to the satisfaction of the Authority.

(4) Installations referred to in sub-regulation (1) of this regulation which release substances which may be hazardous to personnel shall be provided with means of preventing the accidental release of the substance into the space and with pre-release audio and visual alarms in the machinery space warning the crew of the impending release of the harmful substance.

(5) The complete system shall be to the satisfaction of the Authority.

(6) In all machinery spaces, at least one portable fire extinguisher per 75 kW of installed main engine power shall be fitted to a maximum of 6 extinguishers.

(7) At least 50% of these extinguishers shall be of the foam type with the remainder being Dry Powder or Carbon dioxide.

(8) One portable extinguisher shall be stowed as near to the entrance of the machinery space as is practicable.

(9) The Authority may require the provision of additional portable fire extinguishers if, in the opinion of the surveyor, such extinguishers are required.

(10) Where fixed fire-extinguishing systems, not required by this Chapter are

installed, such systems shall be to the satisfaction of the Authority.

109. Fireman's Outfits

- (1) Vessels over 35 metres in length shall be provided with at least two fireman's outfits, stored as to be accessible and ready for use. The fireman's outfit shall consist of:
- (a) a breathing apparatus approved by the Authority; and
 - (b) personal equipment, approved by the Authority, comprising:
 - (i) protective clothing of material to protect the skin of the entire body from the heat radiating from a fire and from burns and scalding by steam. The outer surface shall be water resistant;
 - (ii) boots and gloves of rubber or other electrically non-conducting material;
 - (iii) a rigid helmet providing effective protection against impact;
 - (iv) a portable self-contained battery-operated safety lamp of the lantern type capable of functioning efficiently for at least three hours;
 - (v) a firemen's axe with an electrically insulated handle; and,
 - (vi) a fire resistant life-line.

110. Availability of Fire Appliances

- (1) Fire appliances carried in every ship shall be maintained in good working order and shall be kept available for immediate use at all times.

- (2) All moveable fire appliances, other than firemen's outfits, carried in compliance with this Chapter shall be stowed where they will be readily accessible from the spaces in which they are intended to be used, and, in particular, one of the portable fire extinguishers intended for use in any space shall be stowed near the entrance to that space.

111. Equivalents, Approval of Types and Servicing of Fire Appliances

- (1) Where this Chapter requires that a particular fitting, material, appliance or apparatus, or type thereof, be fitted or carried in a ship, or that a particular provision be made, the Authority may allow any other fitting, material, appliance, apparatus or type thereof, to be fitted or carried, or any other provision to be made in the vessel if satisfied that such other fitting, material, appliance, apparatus or type thereof, or provision, is at least as effective as that required by this Chapter.
- (2) The Authority may approve any type of fire appliance for use on a vessel belonging to the Republic which in the opinion of the Authority complies with the requirements of these Regulations.
- (3) The number, type and position of portable and fixed fire appliances carried on vessels shall be approved by the Authority.
- (4) All fire-fighting appliances shall be serviced at intervals not exceeding 12 months by approved service stations as published by the Authority in Marine Notices which may be updated from time to time.

112. Use of Halon

- (1) Halon or other fire fighting mediums containing Chloro-Fluoro- Carbons

(CFC's) shall not be used as an extinguishing medium on board vessels.

- (2) Fire extinguisher standards and the servicing standards are determined by NRS or SAQCC.

PART B - FIRE SAFETY MEASURES IN VESSELS OF 60 METRES IN LENGTH AND OVER

113. General

- (1) One of the following methods of protection shall be adopted in accommodation and service spaces:
- (a) *Methods IF* - The construction of all internal divisional bulkheads of non-combustible "B" or "C" Class divisions generally without the installation of a detection or sprinkler system in the accommodation and services spaces;
- (b) *Methods IIF* - The fitting of an automatic sprinkler and fire alarm system for the detection and extinction of fire in all spaces in which fire might be expected to originate, generally with no restriction on the type of internal divisional bulkheads; or
- (c) *Method IIIF* - The fitting of an automatic fire alarm and detection system in all spaces in which a fire might be expected to originate, generally with no restriction on the type of internal divisional bulkheads, except that in no case shall the area of any accommodation space or spaces bounded by an "A" or "B" Class division exceed 50 square metres. However, the Authority may increase this area for public spaces.

- (2) The requirements for the use of non-combustible materials in construction and insulation of the boundary bulkheads of machinery spaces, control stations, etc., and the protection of stairway enclosures and corridors shall be common to all three methods.

114. Structure

- (1) The hull, superstructure, structural bulkheads, decks and deckhouses shall be constructed of steel or other equivalent material except as otherwise specified in sub-regulation (4) of this regulation.
- (2) The insulation of aluminium alloy components of “A” or “B” Class divisions, except structures which, in the opinion of the Authority, are non-load bearing, shall be such that the temperature of the structural core does not rise more than 200 degrees celsius above the ambient temperature at any time during the applicable fire exposure to the standard fire test.
- (3) Special attention shall be given to the insulation of aluminium alloy components of columns, stanchions and other structural members required to support survival craft stowage, launching and embarkation areas, and “A” and “B” Class divisions, to ensure:
 - (a) that for such members supporting survival craft areas and “A” Class divisions the temperature rise limitation specified in sub-regulation (2) of this regulation shall apply at the end of one hour; and
 - (b) that for such members required to support “B” Class divisions, the temperature rise limitation specified in sub-regulation (2) of this regulation shall apply at the end of one half-hour.
- (4) Crowns and casings of machinery spaces of Category A shall be of steel construction adequately insulated and any openings therein shall be suitably

arranged and protected to prevent the spread of fire.

115. Bulkheads within the Accommodation and Service Spaces

- (1) Within the accommodation and service spaces, all bulkheads required to be “B” Class divisions shall extend from deck to deck and to the shell or other boundaries, unless continuous “B” Class ceilings or linings, or both, are fitted on both sides of the bulkheads in which case the bulkhead may terminate at the continuous ceiling or lining.
- (2) **Method IF.** All bulkheads not required by this or other Regulations of this Part to be “A” or “B” Class divisions shall be at least “C” Class divisions.
- (3) **Methods IIF.** There shall be no restriction on the construction of bulkheads not required by this or other Regulations of this Part to be “A” or “B” Class divisions except in individual cases where “C” Class bulkheads are required in accordance with Table 1 in regulation 118.
- (4) **Method IIIF.** There shall be no restriction on the construction of bulkheads not required by this or other Regulations of this Part to be “A” or “B” Class divisions. In no case shall the area of any accommodation space or spaces bounded by a continuous “A” or “B” Class division exceed 50 square metres, except in individual cases where “C” Class bulkheads are required in accordance with Table 1 in regulation 118. However, the Authority may increase this area for public spaces.

116. Protection of Stairways and Lift Trunks in Accommodation Spaces, Service Spaces and Control Stations

- (1) Stairways which penetrate only a single deck shall be protected at least at

one level by at least “B-O” Class divisions and self-closing doors.

- (2) Lifts which penetrate only a single deck shall be enclosed by “A-O” Class divisions with steel doors at both levels.
- (3) Stairways and lift trunks which penetrate more than a single deck shall be enclosed by at least “A-O” Class divisions and protected by self-closing [steel!!!] doors at all levels.
- (4) All stairways shall be of steel frame construction except where the Authority permits the use of other equivalent material.

117. Doors in Fire-Resistant Divisions

- (1) Doors shall have resistance to fire as far as practicable, equivalent to the division in which they are fitted.
- (2) Doors and door frames in “A” Class divisions shall be constructed of steel.
- (3) Doors in “B” Class divisions shall be non-combustible.
- (4) Doors fitted in boundary bulkheads of machinery spaces of Category A shall be self-closing and reasonably gas-tight.
- (5) The Authority may permit the use of combustible materials in doors separating cabins from the individual interior sanitary accommodation, such as showers, if constructed according to Method IF.
- (6) Doors required to be self-closing shall not be fitted with hold-back hooks. However, hold-back arrangements fitted with remote release fittings of the fail-safe type may be used.
- (7) Ventilation openings may be permitted in and under the doors in corridor bulkheads except that such openings shall not be permitted in and under

stairway enclosure doors.

- (8) The openings referred to in sub-regulation (7) of this regulation shall be provided only in the lower half of a door and where such opening is in or under a door the total net area of any such opening or openings shall not exceed 0.05 square metres.
- (9) When such opening is cut in a door it shall be fitted with a grill and closing slide made of non-combustible material.
- (10) Watertight doors need not be insulated.

118. Fire Integrity of Bulkheads and Decks

- (1) In addition to the specific provisions for fire integrity of bulkheads and decks required elsewhere in this Part the minimum fire integrity of bulkheads and decks shall be as prescribed in Table 1 and Table 2 of this regulation.
- (2) The following requirements shall govern application of the Tables:
 - (a) Tables 1 and 2 shall apply respectively to bulkheads and decks separating adjacent spaces; and
 - (b) for determining the appropriate fire integrity standards to be applied to divisions between adjacent spaces, such spaces are classified according to their fire risk as follows:

(i) **Control Stations (1)**

Spaces containing emergency sources of power and lighting.

Wheelhouse and chartroom.

Spaces containing the vessel's radio equipment.

Fire-extinguishing rooms, fire-control rooms and fire-recording stations. Control room for propulsion machinery when

located outside the machinery space.

Spaces containing centralized fire alarm equipment.

(ii) **Corridors (2)**

Corridors and lobbies.

(iii) **Accommodation Spaces (3)**

Spaces as defined in Regulation 2(3) and 2(35) excluding corridors.

(iv) **Stairways (4)**

Interior stairways, lifts and escalators other than those wholly contained within the machinery spaces and enclosures thereto. In this connexion, a stairway which is enclosed only at one level shall be regarded as part of the space from which it is not separated by a fire door.

(v) **Service Spaces of Low Fire Risk (5)**

Lockers and store-rooms having areas of less than 2 square metres, drying rooms and laundries.

(vi) **Machinery Spaces of Category A (6)**

Spaces as defined in Regulation 2(44).

(vii) **Other Machinery Spaces (7)**

Spaces as defined in Regulation 2(45) including fishmeal processing spaces, but excluding machinery spaces of Category A.

(viii) **Cargo Spaces (8)**

All spaces used for cargo [fish], including cargo oil ["fish oil"] tanks, and trunk ways and hatchways to such spaces.

(ix) **Service Spaces of High Fire Risk (9)**

Galleys, pantries containing cooking appliances, paint rooms, lamp rooms, lockers and store-rooms having area of 2 square metres or more, and workshops other than those forming part of the machinery spaces.

(x) **Open Decks (10)**

Open deck spaces and enclosed promenades, spaces for processing fish in the raw state, fish washing spaces and similar

spaces containing no fire risk. The air spaces outside superstructures and deckhouses.

The title of each category is intended to be typical rather than restrictive. The number in parenthesis following each category refers to the applicable column or row in the following tables.

| Spaces | _1 | _2 | _3 | _4 | _5 | _6 | _7 | _8 | _9 | _10 |
|---|--------------------|-----|------|---------------------------|---------------------------|------|--------------------|------|--------------------|-----|
| Control Stations (1) | A-0 ^(e) | A-0 | A-60 | A-0 | A-15 | A-60 | A-15 | A-60 | A-60 | * |
| Corridors (2) | | C | B-0 | B-0 A-0 ^(c) | B-0 | A-60 | A-0 | A-0 | A-0 | * |
| Accommodation Spaces (3) | | | C | B-0 A-0 ^(c) | B-0 | A-60 | A-0 | A-0 | A-0 | * |
| Stairways (4) | | | | B-0 A-0 ^(c) | B-0 A-0 ^(c) | A-60 | A-0 | A-0 | A-0 | * |
| Service Spaces of Low Fire Risk (5) | | | | | C | A-60 | A-0 | A-0 | A-0 | * |
| Machinery Spaces of Category A (6) | | | | | | * | A-0 | A-0 | A-60 | * |
| Other Machinery Spaces (7) | | | | | | | A-0 ^(d) | A-0 | A-0 | * |
| Cargo Spaces (8) | | | | | | | | * | A-0 | * |
| Service Spaces of High Fire Risk (9) | | | | | | | | | A-0 ^(d) | * |
| Open Decks (10) | | | | | | | | | | - |

TABLE 1- FIRE INTEGRITY OF BULKHEADS SEPARATING ADJACENT SPACES

| Spaces Below □ Above | Space | _1 | _2 | _3 | _4 | _5 | _6 | _7 | _8 | _9 | _10 |
|--------------------------------------|-------|------|------|------|------|------|------|------|------|--------------------|-----|
| Control Stations (1) | | A-0 | A-0 | A-0 | A-0 | A-0 | A-60 | A-0 | A-0 | A-0 | * |
| Corridors (2) | | A-0 | * | * | A-0 | * | A-60 | A-0 | A-0 | A-0 | * |
| Accommodation Spaces (3) | | A-60 | A-0 | * | A-0 | * | A-60 | A-0 | A-0 | A-0 | * |
| Stairways (4) | | A-0 | A-0 | A-0 | * | A-0 | A-60 | A-0 | A-0 | A-0 | * |
| Service Spaces of Low Fire Risk (5) | | A-15 | A-0 | A-0 | A-0 | * | A-60 | A-0 | A-0 | A-0 | * |
| Machinery Spaces of Category A (6) | | A-60 | A-60 | A-60 | A-60 | A-60 | * | A-60 | A-30 | A-60 | * |
| Other Machinery Spaces (7) | | A-15 | A-0 | A-0 | A-0 | A-0 | A-0 | * | A-0 | A-0 | * |
| Cargo Spaces (8) | | A-60 | A-0 | A-0 | A-0 | A-0 | A-0 | A-0 | * | A-0 | * |
| Service Spaces of High Fire Risk (9) | | A-60 | A-0 | A-0 | A-0 | A-0 | A-0 | A-0 | A-0 | A-0 ^(d) | * |
| Open Decks (10) | | * | * | * | * | * | * | * | * | * | - |

TABLE 2 - FIRE INTEGRITY OF DECKS SEPARATING ADJACENT SPACES

Notes: To be applied to both Tables 1 and 2, as appropriate.

- (a) No special requirements are imposed upon these bulkheads in Methods IIF and IIIF fire protection.
- (b) In case of Method IIIIF "B" Class bulkheads of "B-0" rating shall be provided between spaces or groups of spaces of 50 square metres and over in area.
- (c) For clarification as to which applies see Regulations 17 and 18.
- (d) Where spaces are of the same numerical category and superscript (d) appears, a bulkhead or deck of the rating shown in the Tables is only

required when the adjacent spaces are for a different purpose, e.g. in category (9). A galley next to a galley does not require a bulkhead but a galley next to a paint room requires an "A-0" bulkhead.

(e) Bulkheads separating the wheelhouse, chartroom and radio room from each other may be "B-0" rating.

(f) Fire insulation need not fitted if the machinery space in category (7) in the opinion of the Authority has little or no fire risk.

** Where an asterisk appears in the Tables the division is required to be of steel or equivalent material but is not required to be of "A" Class standard.*

(3) Continuous "B" Class ceilings or linings, in association with the relevant decks or bulkheads, may be accepted as contributing, wholly or in part, to the required insulation and integrity of a division.

(4) Windows and skylights to machinery spaces shall be as follows:

(a) where skylights can be opened they shall be capable of being closed from outside the space. Skylights containing panels shall be fitted with external shutters of steel or other equivalent material permanently attached;

(b) glass or similar materials shall not be fitted in machinery space boundaries. This does not preclude the use of wire-reinforced glass for skylights and glass in control rooms within the machinery spaces; and

(c) in skylights referred to in paragraph (a) of this sub-regulation wire-reinforced glass shall be used.

(5) External boundaries which are required by regulation 114(1) to be of steel or equivalent material may be pierced for the fitting of windows and side-scuttles provided that there is no requirement elsewhere in this Part for such boundaries to have "A" Class integrity.

(6) Similarly, in such boundaries which are not required to have "A" Class

integrity, doors may be of materials to the satisfaction of the Authority.

119. Details of Construction

- (1) **Method IF.** In accommodation and service spaces and control stations all linings, draught stops, ceilings and their associated grounds shall be of non-combustible materials.
- (2) **Methods IIF and IIIF.** In corridors and stairways enclosures serving accommodation and service spaces and control stations, ceilings, linings, draught stops and their associated grounds shall be of non-combustible materials.
- (3) **Methods IF, IIF and IIIF**
 - (a) Except in cargo spaces or refrigerated compartments of service spaces insulating materials shall be non-combustible. Vapour barriers and adhesives used in conjunction with insulation as well as the insulation of pipe fittings, for cold service systems need not be of non-combustible material, but they shall be kept to the minimum quantity practicable and their exposed surfaces shall have qualities of resistance to the propagation of flame to the satisfaction of the Authority. In spaces where penetration of oil products is possible, the surface of insulation shall be impervious to oil or oil vapour;
 - (b) where non-combustible bulkheads, linings and ceilings are fitted in accommodation and service spaces they may have a combustible veneer not exceeding 2.0 millimetres in thickness within any such space except corridors, stairway enclosures and control stations, where it shall not exceed 1.5 millimetres in thickness; and
 - (c) air spaces enclosed behind ceilings, panellings, or linings shall be divided by close-fitting draught stops spaced not more than 14 metres apart. In the vertical direction, such spaces, including those behind

linings of stairways, trunks, etc., shall be closed at each deck.

120. Ventilation Systems

- (1) (a) Ventilation ducts shall be of non-combustible material;
- (b) short ducts, however, not generally exceeding 2 metres in length and with a cross section not exceeding 0.02 square metres need not be non-combustible, subject to the following conditions:
- (i) these ducts shall be of a material which, to the satisfaction of the Authority, has a low fire risk;
 - (ii) they may only be used at the end of the ventilation device; and
 - (iii) they shall not be situated less than 600 millimetres, measured along the duct, from an opening in an “A” or “B” Class division including continuous “B” Class ceilings.
- (c) where the ventilation ducts with a free cross-sectional area exceeding 0.02 square metres pass through “A” Class bulkheads or decks, the opening shall be lined with a steel sheet unless the ducts passing through the bulkheads or decks are of steel in the vicinity of passage through the deck or bulkhead and comply in that portion of the duct with the following:
- (i) for ducts with a free cross-sectional area exceeding 0.02 square metres the sleeves shall have a thickness of at least 3 millimetres and a length of at least 900 millimetres. When passing through bulkheads this length shall preferably be divided evenly on each side of the bulkhead. Ducts with a free cross-sectional area exceeding 0.02 square metres shall be provided with fire insulation. The insulation shall have at least the same fire integrity as the bulkhead or deck through which the duct passes. Equivalent penetration protection may be provided to the satisfaction of the Authority; and

- (ii) ducts with a free cross-sectional area exceeding 0.075 square metres shall be fitted with fire dampers in addition to the requirements of paragraph (b)(i). The fire damper shall operate automatically but shall also be capable of being closed manually from both sides of the bulkhead or deck. The damper shall be provided with an indicator which shows whether the damper is open or closed. Fire dampers are not required, however, where ducts pass through spaces surrounded by “A” Class divisions, without serving those spaces, provided those ducts have the same fire integrity as the bulkheads which they penetrate.
- (d) Ventilation ducts for machinery spaces of Category A or galleys shall not in general pass through accommodation spaces, service spaces or control stations.
- (e) Where the Authority permits arrangement referred to in paragraph (c) of this sub-regulation , the ducts shall be constructed of steel or equivalent material and so arranged as to preserve the integrity of the divisions.
- (f) Ventilation ducts of accommodation spaces, service spaces or control stations shall not in general pass through machinery spaces of Category A or through galleys.
- (g) Where the Authority permits arrangement referred to in paragraph (e) of this sub-regulation the ducts shall be constructed of steel of equivalent material and so arranged as to preserve the integrity of the divisions.
- (h) Where ventilation ducts with a free cross-sectional area exceeding 0.02 square metres pass through “B” Class bulkheads the openings shall be lined with steel sheet sleeves of at least 900 millimetres in length, unless the ducts are of steel for this length in way of the bulkheads.
- (i) When passing through a “B” Class bulkhead this length referred to in paragraph (g) of this sub-regulation shall preferably be divided evenly

on each side of the bulkhead.

- (j) Such measures as are practicable shall be taken in respect of control stations outside machinery spaces in order to ensure that ventilation, visibility and freedom from smoke are maintained, so that in the event of fire the machinery and equipment contained therein may be supervised and continue to function effectively.
 - (j) Alternative and separate means of air supply shall be provided; air inlets of the two sources of supply shall be so disposed that the risk of both inlets drawing in smoke simultaneously is minimized.
 - (k) At the discretion of the Authority, such requirements need not apply to control stations situated on, and opening on to, an open deck, or where local closing arrangements are equally effective.
 - (l) Where they pass through accommodation space or spaces containing combustible materials, the exhaust ducts from galley ranges shall be constructed of "A" Class divisions. Each exhaust duct shall be fitted with:
 - (i) a grease trap readily removable for cleaning;
 - (ii) a fire damper located in the lower end of the duct;
 - (iii) arrangements, operable from within the galley, for shutting off the exhaust fan; and
 - (iv) fixed means for extinguishing a fire within the duct, except where the Authority considers such fittings impractical in a vessel of less than 75 metres in length.
- (3) The main inlets and outlets of all ventilation systems shall be capable of being closed from outside the spaces being ventilated.
- (4) Power ventilation of accommodation spaces, service spaces, control stations and machinery spaces shall be capable of being stopped from an easily

accessible position outside the space being served.

- (5) The position referred to sub-regulation (3) of this regulation should not be readily cut off in the event of a fire in the spaces served.
- (6) The means provided for stopping the power ventilation of the machinery spaces shall be entirely separate from the means provided for stopping ventilation of other spaces.
- (6) Means shall be provided for closing from a safe position, the annular spaces around funnels.
- (7) Ventilation systems serving machinery spaces shall be independent of systems serving other spaces.
- (8) Store-rooms containing appreciable quantities of highly flammable products shall be provided with ventilation arrangements which are separate from other ventilation systems.
- (9) Ventilation shall be arranged at high and low levels and the inlets and outlets of ventilators shall be positioned in safe areas and fitted with spark arresters in accordance with regulation 40(3).

121. Heating Installations

- (1) Electric radiators shall be fixed in position and so constructed as to reduce fire risks to a minimum.
- (2) No such radiator shall be fitted with an element so exposed that clothing, curtains or other similar materials can be scorched or set on fire by heat from the element.
- (3) Heating by means of open fires shall not be permitted. All Heating appliances

of any design shall be firmly secured with adequate protection and insulation against the risk of fire.

- (4) Open flame gas appliances, except cooking stoves and water heaters, shall not be permitted.
- (5) Spaces containing any such stove or water heater shall have adequate ventilation supplying combustion air and to remove fumes and possible gas leakage to a safe place.
- (6) All pipes conveying gas from container to such appliance shall be of seamless steel, copper or other approved material.
- (7) An automatic gas shut-off flame failure device shall be fitted on any such appliance
- (8) Where gaseous fuel is used for domestic purposes, the arrangements, storage, distribution and use of the fuel shall be to the satisfaction of the Authority and in accordance with Regulation 30.

121. Remote Fuel Stops

- (1) Machinery driving fuel oil transfer pumps, fuel oil unit pumps and other similar fuel pumps shall be fitted with remote controls situated outside the machinery space concerned so that they can be stopped in the event of a fire arising in the space in which they are located.
- (2) Pipes connected to any oil fuel storage, settling, or daily service tank, not being a double bottom tank, which if damaged would permit discharge of the contents, due to the gravitational head, so as to cause a fire hazard, shall be fitted with a valve or cock which shall be secured to the tank to which it is connected and be capable of being closed from a readily accessible position

outside the space in which the tank is situated.

- (3) In the case of an oil fuel deep tank traversed by any shaft or pipe tunnel, in addition to the valve which shall be fitted on the tank, a valve or valves may be fitted on the pipe line or lines outside of such tunnel to enable safe control to be exercised in the event of fire.

122. Miscellaneous Items

- (1) Exposed surfaces in corridors and stairways enclosures and surfaces including grounds in concealed or inaccessible spaces in accommodation and service spaces and control stations shall have low flame-spread characteristics.
- (2) Exposed surfaces of ceilings in accommodation and service spaces and control stations shall have low flame-spread characteristics.
- (3) Paints, varnishes and other finishes used on exposed interior surfaces shall not be capable of producing excessive quantities of smoke or toxic gases or vapours.
- (4) The Authority shall be satisfied that they are not of a nature to offer an undue fire hazard.
- (5) Primary deck coverings within accommodation and service spaces and control stations, shall be of approved material which will not readily ignite or give rise to toxic or explosive hazards at elevated temperatures.
- (6) Where "A" or "B" Class divisions are penetrated for the passage of electrical cables, pipes, trunks, ducts, etc., or for the fitting of ventilation terminals, lighting fixtures and similar devices, arrangements shall be made to ensure that the fire integrity of the divisions is not impaired.
- (7) In accommodation and service spaces and control stations, pipes

penetrating "A" or "B" Class divisions shall be of approved materials having regard to the temperature such divisions are required to withstand.

- (8) Where the Authority permits the conveying of oil and combustible liquids through accommodation and service spaces, the pipes conveying oil or combustible liquids shall be of an approved material having regard to the fire risk.
- (9) Materials readily rendered ineffective by heat shall not be used for overboard scuppers, sanitary discharges, and other outlets which are close to the waterline and where the failure of the material in the event of fire would give rise to danger of flooding.
- (10) All waste receptacles other than those used in fish processing shall be constructed of non-combustible materials with no openings in the sides or bottom.
- (11) Every possible precaution shall be taken to avoid fuel and lubricating oil running into the bilges.
- (12) Drip trays with proper means of drainage to a drain tank or save-all shall be provided under fuel tank outlets and, where possible, under engines.
- (13) Within compartments used for stowage of fish, combustible insulation shall be protected by close-fitting cladding.

123. Storage of Gas Cylinders and Dangerous Materials

- (1) Cylinders for compressed, liquefied or dissolved gases shall be clearly marked by means of prescribed identifying colours, have a clearly legible identification of the name and chemical formula of their contents and be properly secured.
- (2) (a) Cylinders containing flammable or other dangerous gases and empty cylinders shall be stored, properly secured, on open decks and all valves,

pressure regulators and pipes leading from such cylinders shall be protected against damage;

(b) Cylinders shall be protected against excessive variations in temperature direct rays of the sun, and accumulation of snow; and

(c) However, the Authority may permit such cylinders to be stored in compartments complying with the requirements of sub-regulations (3) to (5).

(3) (a) Spaces containing highly flammable liquids, such as volatile paints, paraffin, benzole, etc., and where permitted, liquefied gas, shall have direct access from open decks only;

(b) Pressure-adjusting devices and relief valves shall exhaust within the compartment;

(c) Where boundary bulkheads of such compartments adjoin other enclosed spaces they shall be gastight; and

(d) Ventilation of such spaces shall be in accordance with Regulation 120(9).

(4) (a) Except as necessary for service within the space, electrical wiring and fittings shall not be permitted within compartments used for the storage of highly flammable liquids or liquefied gases;

(b) Where such electrical fittings are installed, they shall be to the satisfaction of the Authority for use in a flammable atmosphere;

(c) Sources of heat shall be kept clear of such spaces and "No Smoking" and "No Naked Light" notices shall be displayed in a prominent position.

(5) (a) Separate storage shall be provided for each type of compressed gas;

- (b) Compartments used for the storage of such gases shall not be used for storage of other combustible products nor for tools or objects not part of the gas distribution system;
- (c) However, the Authority may relax these requirements considering the characteristics; and
- (d) Volume and intended use of such compressed gases.

124. Means of Escape

- (1) Stairways and ladders leading to and from all accommodation spaces and in spaces in which the crew is normally employed, other than machinery spaces, shall be so arranged as to provide ready means of escape to the open deck and thence to the survival craft. In particular in relation to these spaces:
 - (a) at all levels of accommodation at least two widely separate means of escape shall be provided which may include the normal means of access from each restricted space or group of spaces;
 - (b)
 - (i) below the weather deck the main means of escape shall be a stairway and the second escape may be a trunk or a stairway; and
 - (ii) above the weather deck the means of escape shall be stairways or doors to an open deck or a combination thereof. Where it is not practical to fit stairways or doors, one of these means of escape may be by means of an adequately sized porthole or hatch protected, where necessary, against ice accretion;
 - (c) exceptionally the Authority may permit only one means of escape, due regard being paid to the nature and location of spaces and to the

- number of persons who normally might be accommodated or employed there. The Authority will only consider reducing the number of escapes in cases where 10 persons or less are accommodated in a space;
- (d) a corridor or part of a corridor from which there is only one route of escape, shall not exceed 7 metres in length; and
 - (e) the width and continuity of the means of escape shall be to the satisfaction of the Authority.
- (2) Two means of escape shall be provided from every machinery space of Category A by one of the following means:
- (a) two sets of steel ladders as widely separated as possible leading to doors in the upper part of the space similarly separated and from which access is provided to the open deck. In general, one of these ladders shall provide continuous fire shelter from the lower part of the space to a safe position outside the space. However, the Authority may not require such shelter if, due to special arrangements or dimensions of the machinery space, a safe escape route from the lower part of this space is provided. This shelter shall be of steel, insulated, where necessary, to the satisfaction of the Authority and be provided with a self-closing steel door at the lower end; or
 - (b) one steel ladder leading to a door in the upper part of the space from which access is provided to the open deck and additionally, in the lower part of the space and in a position well separated from the ladder referred to, a steel door capable of being operated from each side and which provides access to a safe escape route from the lower part of the space to the open deck.
- (3) From machinery spaces other than those of Category A, escape routes shall be provided to the satisfaction of the Authority having regard to the nature and location of the space and whether persons are normally employed in that space.

- (4) Lifts shall not be considered as forming one of the required means of escape.

**125. Automatic Sprinkler and Fire Alarm and Fire Detection Systems
(Method IIF)**

- (1) In vessels in which method IIF is adopted an automatic sprinkler and fire alarm system of a approved type and complying with the requirements of this Regulation shall be installed and so arranged as to protect accommodation spaces and service spaces except spaces which afford no substantial fire risks, such as void spaces and sanitary spaces.
- (2) (a) The system shall be capable of immediate operation at all times and no action by the crew shall be necessary to set it in operation;
- (b) It shall be of the wet pipe type but small exposed sections may be of the dry pipe type where in the opinion of the Authority this is a necessary precaution;
- (c) Any parts of the system which may be subjected to freezing temperatures in service shall be suitably protected against freezing; and
- (d) It shall be kept charged at the necessary pressure and shall have provision for a continuous supply of water as required in sub-regulation 6(b).
- (3) (a) Each section of sprinklers shall include means for giving a visible and audible alarm signal automatically at one or more indicating units whenever any sprinkler comes into operation.
- (b) Such units shall indicate in which section served by the system, fire has occurred and shall be centralized in the wheelhouse and in addition, visible and audible alarms from the unit shall be placed in a position other than in the wheelhouse, so as to ensure that the

- indication of fire is immediately received by the crew.
- (c) Such an alarm system shall be so constructed as to indicate if any fault occurs in the system.
- (4) (a) Sprinklers shall be grouped into separate sections, each of which shall contain not more than 200 sprinklers.
- (b) Each section of sprinklers shall be capable of being isolated by one stop valve only. The stop valve in each section shall be readily accessible and its location shall be clearly and permanently indicated. Means shall be provided to prevent the operation of the stop valves by any unauthorized person.
- (c) A gauge indicating the pressure in the system shall be provided at each section stop valve and at a central station.
- (d) The sprinklers shall be resistant to corrosion. In accommodation and service spaces the sprinklers shall come into operation within the temperature range of 68 degrees celsius and 79 degrees celsius, except that in location such as drying rooms, where high ambient temperatures might be expected, the operating temperature may be increased by not more than 30 degrees celsius above the maximum deck head temperature.

- (e) A list or plan shall be displayed at each indicating unit showing the spaces covered and the location of the zone in respect of each section. Suitable instructions for testing and maintenance shall be available.
- (4) Sprinklers shall be placed in an overhead position and spaced in a suitable pattern to maintain an average application rate of not less than 5 litres per square metre per minute over the nominal area covered by the sprinklers. Alternatively, the Authority may permit the use of sprinklers providing such quantity of water suitably distributed as has been shown to the satisfaction of the Authority to be not less effective.
- (5) (a) A pressure tank having a volume equal to at least twice that of the charge of water specified in this sub-paragraph shall be provided. The tank shall contain a standing charge of fresh water, equivalent to the amount of water which would be discharged in one minute by the pump referred to in sub-regulation (6)(b), and the arrangements shall provide for maintaining such air pressure in the tank as to ensure that, where the standing charge of fresh water in the tank has been used, the pressure will be not less than the working pressure of the sprinkler, plus the pressure due to a head of water measured from the bottom of the tank to the highest sprinkler in the system. Suitable means of replenishing the air under pressure and of replenishing the fresh water charge in the tank shall be provided. A glass gauge shall be provided to indicate the correct level of the water in the tank.
- (b) Means shall be provided to prevent the passage of sea-water into the tank.
- (6) (a) An independent power pump shall be provided solely for the purpose of continuing automatically the discharge of water from the sprinklers. The pump shall be brought into action automatically by the pressure drop in the system before the standing fresh water charge in the pressure tank is completely exhausted.

- (b) The pump and the piping system shall be capable of maintaining the necessary pressure at the level of the highest sprinkler to ensure a continuous output of water sufficient for the simultaneous coverage of the maximum area separated by fire-resisting bulkheads of “A” and “B” Class divisions or an area of 280 square metres which-ever is the less at the application rate specified in sub-regulation (4).
 - (c) The pump shall have fitted on the delivery side a test valve with a short open-ended discharge pipe. The effective area through the valve and pipe shall be adequate to permit the release of the required pump output while maintaining the pressure in the system specified in sub-regulation(5)(a).
 - (d) The sea inlet to the pump shall wherever possible be in the space containing the pump and shall be so arranged that when the vessel is afloat it will not be necessary to shut off the supply of sea-water to the pump for any purpose other than the inspection or repair of the pump.
- (4) The sprinkler pump and tank shall be situated in a position reasonably remote from any machinery space of Category A and shall not be situated in any space required to be protected by the sprinkler system.
- (5) (a) There shall not be less than two sources of power supply for the sea-water pump and the automatic fire alarm and fire detection system. If the pump is electrically driven it shall be connected to the main source of electrical power, which shall be capable of being supplied by at least two generators.
- (b) The feeders shall be arranged so as to avoid galleys, machinery spaces and other enclosed spaces of high fire risk except in so far as it is necessary to reach the appropriate switchboard. One of the sources of power supply for the fire detection system shall be an emergency source. Where one of the sources of power for the pump is an internal combustion-type engine it shall, in addition to complying with the

provisions of sub-regulation (7), be so situated that a fire in any protected space will not affect the air supply to that engine.

- (6) The sprinkler system shall have a connection from the vessel's fire main by way of a lockable screw-down non-return valve at the connexion which will prevent a backflow from the sprinkler system to the fire main.
- (7)
 - (a) A test valve shall be provided for testing the automatic alarm for each section of sprinklers by a discharge of water equivalent to the operation of one sprinkler. The test valve for each section shall be situated near the stop valve for that section.
 - (b) Means shall be provided for testing the automatic operation of the pump on reduction of pressure in the system.
 - (c) Switches shall be provided at one of the indicating positions referred to in sub-regulation 2(b) which will enable the alarm and the indicators for each section of sprinklers to be tested.
- (8) Spare sprinkler heads shall be provided for each section of sprinklers to the satisfaction of the Authority.

126. Automatic Fire Alarm and Fire Detection Systems
(Method IIIF)

- (1) In vessels in which Method IIIF is adopted an automatic fire alarm and fire detection system of an approved type and complying with the requirements of this regulation shall be installed and so arranged as to detect the presence of fire in all accommodation spaces and service spaces except spaces which afford no substantial fire risk, such as void spaces and sanitary spaces.
- (2)
 - (a) The system shall be capable of immediate operation at all times

and no action of the crew shall be necessary to set it in operation.

- (b) Each section of detectors shall include means for giving a visible and audible alarm signal automatically at one or more indicating units whenever any detector comes into operation.
- (c) Units referred to in sub-paragraph (b) of this sub-regulation shall indicate in which section served by the system a fire has occurred and shall be centralized on the wheelhouse and such other positions as will ensure that any alarm from the system is immediately received by the crew.
- (d) Additionally, arrangements shall be provided to ensure that an alarm is sounded on the deck on which the fire has been detected and such an alarm and detection system shall be so constructed as to indicate if any fault occurs in the system.

- (3) (a) Detectors shall be grouped into separate sections, each covering not more than 50 rooms served by such a system and containing not more than 100 detectors; and
- (b) Detectors shall be zoned to indicate on which deck a fire has occurred.
- (4) (a) The system shall be operated by an abnormal air temperature, by an abnormal concentration of smoke or by other factors indicative of incipient fire in any one of the spaces to be protected;
- (b) Systems which are sensitive to air temperature shall not operate at less than 54 degrees Celsius and shall operate at a temperature not greater than 78 degrees Celsius when the temperature increase to those levels is not more than 1 degree Celsius per minute;
- (c) At the discretion of the Authority the permissible temperature of operation may be increased to 30 degrees Celsius above the maximum deckhead temperature in drying rooms and similar places of a normally high ambient temperature;
- (d) Systems which are sensitive to smoke concentration shall operate on the reduction of the intensity of a transmitted light beam by an amount to be determined by the Authority;
- (e) Other equally effective methods of operation may be accepted at the discretion of the Authority;and
- (f) The detection system shall not be used for any purpose other than fire detection.
- (5) (a) The detectors:
- (i) may be arranged to operate the alarm by the opening or closing of contacts or by other appropriate methods;
- (ii) shall be fitted in an overhead position and shall be suitably protected against impact and physical damage;

- (iii) shall be suitable for use in a marine atmosphere ;and
 - (iv) shall be placed in an open position clear of beams and other objects likely to obstruct the flow of hot gases or smoke to the sensitive element.
- (b) Detectors operated by the closing of contacts shall be of the sealed contact type and the circuit shall be continuously monitored to indicate fault conditions.
- (6) (a) At least one detector shall be installed in each space where detection facilities are required and there shall be not less than one detector for each 37 square metres of deck area approximately.
- (b) In large spaces the detectors shall be arranged in a regular pattern so that no detector is more than 9 metres from another detector or more than 4.5 metres from a bulkhead.
- (7) (a) There shall be not less than two sources of power supply for the electrical equipment used in the operation of the fire alarm and fire detection system, one of which shall be an emergency source.
- (b) The supply shall be provided by separate feeders reserved solely for that purpose.
- (c) feeders shall run to a change-over switch situated in the control station for the fire detection system.
- (d) The wiring system shall be so arranged as to avoid galleys, machinery spaces and other enclosed spaces having a high fire risk except in so far as it is necessary to provide for fire detection in such spaces or to reach the appropriate switchboard.
- (8) (a) A list or plan shall be displayed adjacent to each indicating unit showing the spaces covered and the location of the zone in respect of each system and suitable instructions for testing and maintenance shall be available.

- (b) Provision shall be made for testing the correct operation of the detectors and the indicating units by supplying means for applying hot air or smoke at detector positions.
- (9) Spare detector heads shall be provided for each section of detectors to the satisfaction of the Authority.

127. Fixed Fire-Extinguishing Arrangements in Holds and Spaces of High Fire Risk

Holds and spaces of high fire risk shall be protected by a fixed gas fire-extinguishing system or by a fire-extinguishing system which gives equivalent protection, to the satisfaction of the Authority.

128. Fire Pumps

- (1) At least two fire pumps shall be provided.
- (2) (a) If a fire in any one compartment could put all the fire pumps out of action, there shall be an alternative means of providing water for fire fighting.
 - (b) This alternative means shall be a fixed emergency fire pump independently driven.
 - (c) The emergency fire pump shall be capable of supplying two jets of water to the satisfaction of the Authority.
- (3) (a) The fire pumps, other than the emergency pump shall be capable of delivering for fire-fighting purposes a quantity of water at a minimum pressure of 0.25 Newtons per square millimetre, with a total capacity (Q) of at least:

$$Q = (0.15 \square L(B + D) + 2.25)^2 \text{ cubic metres per hour}$$

where L, B and D are in metres.

(0.25 MPa or 2.5Bar)

However, the total required capacity of the fire pumps need not exceed 180 cubic metres per hour;

- (b) Each of the required fire pumps other than any emergency pump shall have a capacity not less than 40 per cent of the total capacity of fire pumps required by paragraph (a) and shall in any event be capable of delivering at least the jets of water required by Regulation 128(2)(a);
 - (c) These fire pumps shall be capable of supplying the fire main systems under the required conditions; and
 - (d) Where more than two pumps are installed the capacity of such additional pumps shall be to the satisfaction of the Authority.
- (4)
- (a) Fire pumps shall be independently driven power pumps and sanitary, ballast, bilge or general service pumps may be accepted as fire pumps, provided that they are not used for pumping oil or oily water;
 - (b) Relief valves shall be provided in conjunction with all fire pumps if the pumps are capable of developing a pressure exceeding the design pressure of the water service pipes, hydrants and hoses;
 - (c) Valves referred to in paragraph (b) of this sub-regulation shall be so placed and adjusted as to prevent excessive pressure in any of the fire main systems;
 - (d) Emergency power-operated fire pumps shall be independently driven self-contained pumps either with their own diesel engine prime mover and fuel supply fitted in an accessible position outside the compartment which contains the main fire pumps, or be driven by a self-contained generator, which may be the emergency generator referred to in regulation 87 of sufficient capacity and which is positioned in a safe place outside the engine room and preferably above the working deck;

- (e) The emergency fire pump shall be capable of operating for a period of at least 3 hours; and
- (f) Emergency fire pumps, sea-suction valves and other necessary valves shall be operable from outside compartments containing main fire pumps in a position not likely to be cut off by a fire in those compartments.

129. Fire Mains

- (1)
 - (a) Where more than one hydrant is required to provide the number of jets specified in regulation 130(2)(a) a fire main shall be provided;
 - (b) Fire mains shall have no connections other than those required for fire fighting except for the purpose of washing the deck and anchor chains or operating the chain locker bilge ejector, subject to the efficiency of the fire fighting system be maintained; and
 - (c) Where fire mains are not self-draining, suitable drain cocks shall be fitted where frost or ice damage could be expected.
- (2)
 - (a) The diameter of the fire main and water service pipes shall be sufficient for the effective distribution of the maximum required discharge from two fire pumps operating simultaneously or of 140 cubic metres per hour, whichever is the less; and
 - (b) With the two pumps simultaneously delivering through nozzles specified in regulation 128(5) the quantity of water specified in paragraph (a) of this sub-regulation, through any adjacent hydrants, the minimum pressure of 0.25 Newtons per square millimetre shall be maintained at all hydrants.

130. Fire Hydrants, Fire Hoses and Nozzles

- (1) (a) The number of fire hoses provided shall be equal to the number of fire hydrants arranged according to sub-regulation (2) of this regulation and one spare hose and:
- (i) this number does not include any fire hoses required in any engine or boiler room; and
 - (ii) the Authority may increase the number of fire hoses required so as to ensure that hoses in sufficient number are available and accessible at all times, having regard to the size of the vessel;
- (b) Fire hoses shall be of approved material and sufficient in length to project a jet of water to any of the spaces in which they may be required to be used and their maximum length shall be 20 metres;
- (c) Every fire hose shall be provided with a nozzle and the necessary couplings; and
- (d) Fire hoses shall together with any necessary fittings and tools be kept ready for use in conspicuous positions near the water service hydrants or connections.
- (2) (a) The number and position of the hydrants shall be such that at least two jets of water not emanating from the same hydrant, one of which shall be from a single length of fire hose, may reach any part of the vessel normally accessible to the crew while the vessel is being navigated;
- (b) All required hydrants shall be fitted with fire hoses having jet or spray nozzles as required by sub-regulation (5); and
- (c) One hydrant shall be located near the entrance of the space to be

protected.

- (3) (a) Materials readily rendered ineffective by heat shall not be used for fire mains and hydrants unless adequately protected;
- (b) the pipes and hydrants shall be so placed that the fire hoses may be easily coupled to them;
- (c) the positions of the hydrants shall be such that they are always readily accessible and the pipes shall be arranged as far as practicable to avoid risk of damage; and
- (d) unless one fire hose and nozzle is provided for each hydrant, there shall be complete inter-changeability of fire hose couplings and nozzles.
- (4) A cock or valve shall be fitted to serve each fire hose so that any fire hose may be removed while the fire pumps are operating.
- (5) (a) Standard nozzle sizes shall be 12 millimetres, 16 millimetres and 19 millimetres or as near thereto as possible. Larger diameter nozzles may be permitted at the discretion of the Authority.
- (b) For accommodation and service spaces, a nozzle size greater than 12 millimetres need not be used.
- (c) For machinery spaces and exterior locations, the nozzle size shall be such as to obtain the maximum discharge possible for two jets at the pressure specified in Regulation 34 (2) (b) from the smallest pump provided that a nozzle size greater than 19 millimetres need not be used.

131. Fire Extinguishers

- (1) Fire extinguishers shall be of approved types.
- (2) Every fire extinguisher provided in compliance with this Chapter shall be constructed in accordance with the specifications published by the Authority by Marine Notice which may be up-dated from time to time.
- (3) The capacity of required portable fire extinguishers (other than carbon dioxide extinguishers) shall be not more than 13.5 litres and not less than 9 litres. Other extinguisher shall not be in excess of the equivalent portability of the 13.5 litre fluid extinguisher and shall not less than the fire-extinguishing equivalents of a 9 litre fluid extinguisher.
- (4) The Authority shall determine the equivalents of fire extinguishers.
- (5) Fire extinguishers containing an extinguishing medium which in the opinion of the Authority, either by itself or under expected conditions of use, gives off toxic gases in such quantities as to endanger persons shall not be permitted or shall be subject to safety measures as determined by the Authority.
- (6) Normally, one of the fire extinguishers intended for use in any space shall be stowed near an entrance to that space.

132. Portable Fire Extinguishers and Fire Blankets in Control Stations and Accommodation and Service Spaces

- (1) A sufficient number of approved portable fire extinguishers shall be provided in control stations and accommodation and service spaces to ensure that at

least one extinguisher, of a suitable type, is readily available for use in any part of such spaces. The total number of extinguishers in these spaces shall however not be less than five.

- (2) Where portable dry powder extinguishers are provided in either accommodation and service spaces or in machinery spaces, their numbers shall not exceed 50% of the total number of extinguishers provided in either of those spaces.
- (3) Every galley is to be provided with a fire blanket which is to be mounted on a bulkhead near an access doorway in a position allowing easy retrieval.

133. Fire-Extinguishing Appliances in Machinery Spaces

- (1) (a) Spaces containing oil-fired boilers or fuel oil units shall be provided with one of the following fixed fire-extinguishing systems, to the satisfaction of the Authority:
 - (i) a pressure water-spraying installation;
 - (ii) a fire-smothering gas installation;
 - (iii) a fire-extinguishing using high expansion foam; or,
 - (iv) a fire-extinguishing installation using low toxicity vapourizing liquids.

Where the engine and boiler rooms are not entirely separate, or if fuel oil can drain from the boiler room into the engine room, the combined engine and boiler rooms shall be considered as one compartment;

- (b) Every boiler room shall be provided with at least one set of portable air foam equipment to the satisfaction of the Authority;
- (c) At least two approved portable extinguishers discharging foam or

equivalent shall be provided in each firing space in each boiler room and each space in which a part of the fuel oil installation is situated. At least one approved foam-type extinguisher of at least 135 litres capacity or equivalent shall be provided in each boiler room. These extinguishers shall be provided with hoses on reels suitable for reaching any part of the boiler room. The Authority may relax the requirements of this sub-paragraph, having regard to the size and nature of the space to be protected; and

- (d) In each firing space there shall be a receptacle containing sand, sawdust impregnated with soda or other approved dry material, in such quantity as may be required by the Authority. Alternatively an approved portable extinguisher may be provided.
- (2) Spaces containing internal combustion machinery used either for main propulsion or for other purposes, when such machinery has a total power output of not less than 375 kilowatts, shall be provided with the following arrangements:
- (a) one of the fire-extinguishing systems required by sub-regulation (1)(a) of this regulation;
 - (b) at least one set of portable air-foam equipment to the satisfaction of the Authority; and
 - (c) in each such space, approved foam-type fire extinguishers each of at least 45 litres capacity, or equivalent, sufficient in number to enable foam or its equivalent to be directed on to any part of the fuel and lubricating oil pressure systems, gearing and other fire hazards. In addition, there shall be provided a sufficient number of portable foam extinguishers or equivalent which shall be so located that an extinguisher is not more than 10 metres walking distance from any point in the space; provided that there shall be at least two such extinguishers in each such space. For smaller spaces the Authority may relax these requirements.
- (3) Spaces containing steam turbines or enclosed steam engines used either for

main propulsion, or for other purposes, when such machinery has a total power output of not less than 375 kilowatts shall be provided with the following arrangements:

- (a) foam fire extinguishers each of at least 45 litres capacity, or equivalent, sufficient in number to enable foam or its equivalent to be directed on to any part of the pressure lubricated parts of the turbines, engines or associated gearing, and any other fire hazards. Provided that such extinguishers shall not be required if protection at least equivalent to that of this sub-paragraph is provided in such spaces by a fixed fire-extinguishing system fitted in compliance with sub-regulation (1)(a) of this regulation; and
 - (b) a sufficient number of portable foam extinguishers, or equivalent which shall be so located that an extinguisher is not more than 10 metres walking distance from any point in the space; provided that there shall be at least two such extinguishers in each such space, and such extinguishers shall not be required in addition to any provided in compliance with sub-regulation (2)(c) of this regulation.
- (4) Where, in the opinion of the Authority, a fire hazard exists in any machinery space for which no specific provisions for fire-extinguishing appliances are prescribed in sub-regulations (1), (2) and (3) of this regulation there shall be provided in, or adjacent to, that space a number of approved portable fire extinguishers or other means of fire extinction to the satisfaction of the Authority.
- (5) Where fixed fire-extinguishing systems not required by this Regulation are installed, such systems shall be to the satisfaction of the Authority.
- (6) For any machinery space of Category A to which access is provided at a low level from an adjacent shaft tunnel, there shall be provided in addition to any watertight door and on the side remote from that machinery space a light steel fire-screen door which shall be capable of being operated from each side of the door.

134. International Shore Connection

- (1) At least one international shore connection, complying with sub-regulation (2) of this regulation shall be provided.
- (2) Standard dimensions of flanges for the international shore connexion shall be in accordance with the following table:

| Description | Dimension |
|----------------------|--|
| Outside diameter | 178 millimetres |
| Inner diameter | 64 millimetres |
| Bolt circle diameter | 132 millimetres |
| Slots in flange | 4 holes 19 millimetres in diameter equidistantly placed on a bolt circle of the above diameter, slotted to the flange periphery. |
| Flange thickness | 14.5 millimetres minimum |
| Bolts and nuts | 4 each of 16 millimetres in diameter and 50 millimetres in length. |

- (3) This connection shall be constructed of material suitable for 1.0 newton per square millimetre service pressure. (10 Bar or 1MPa)
- (4) The flange shall have a flat face on one side and the other shall have a coupling permanently attached thereto that will fit the vessel's hydrant and hose and the connection shall be kept aboard the vessel together with a gasket of any material suitable for 1.0 newton per square millimetre (10 Bar or 1MPa) service pressure, together with four 16 millimetre bolts 50 millimetres in length and eight washers.
- (5) Facilities shall be available enabling such a connection to be used on either side of the vessel.
- (6) The location of the International Shore Connection shall be clearly marked.

135. Fireman's Outfits

- (1) Vessels shall be provided with at least two fireman's outfits, stored as to be accessible and ready for use. The fireman's outfit shall consist of:
- (a) a breathing apparatus approved by the Authority; and
 - (b) personal equipment comprising:
 - (i) protective clothing of material to protect the skin from the heat radiating from a fire and from burns and scalding by steam. The outer surface shall be water resistant;
 - (ii) boots and gloves of rubber or other electrically non-conducting material;
 - (iii) a rigid helmet providing effective protection against impact;
 - (iv) a portable self-contained battery-operated safety lamp of the lantern type capable of functioning efficiently for at least three hours;
 - (v) a firemen's axe with an electrically insulated handle; and,
 - (vi) a fire resistant life-line.

136. Fire Control Plan

- (1) There shall be a permanently exhibited fire control plan to the satisfaction of the Authority.
- (2) There shall be a copy of this Fire Control Plan placed, in a clearly visible waterproof storage container, at each boarding position of the vessel

137. Availability of Fire Appliances

- (1) Fire appliances carried in every ship shall be maintained in good working order and shall be kept available for immediate use at all times.
- (2) All moveable fire appliances, other than firemen's outfits, carried in compliance with this Chapter shall be stowed where they will be readily accessible from the spaces in which they are intended to be used, and, in particular, one of the portable fire extinguishers intended for use in any space shall be stowed near the entrance to that space.

138. Equivalent, Approval of Types and Servicing of Fire Appliances

- (1) Where this Chapter requires that a particular fitting, material, appliance or apparatus, or type thereof, be fitted or carried in a ship, or that a particular provision be made, the Authority may allow any other fitting, material, appliance, apparatus or type thereof, to be fitted or carried, or any other provision to be made in the vessel if satisfied that such other fitting, material, appliance, apparatus or type thereof, or provision, is at least as effective as that required by this Chapter.
- (2) The Authority may approve any type of fire appliance for use on a vessel belonging to the Republic which in the opinion of the Authority complies with the requirements of these Regulations.
- (3) The number, type and position of portable and fixed fire appliances carried on vessels shall be approved by the Authority.
- (4) All fire-fighting appliances shall be serviced at intervals not exceeding 12 months by an approved service station, in accordance with Marine Notices published by the Authority, which may be updated from time to time.

139. Use of Halons

Halon or other fire fighting mediums containing Chloro-Fluoro- Carbons (CFC's)_shall not be used as an extinguishing medium on board vessels.

**CHAPTER VII
PROTECTION OF THE CREW****140. General Protection Measures**

- (1) Owners and masters shall ensure that the state of cleanliness and lighting of the vessel is such that hazardous conditions are not created for persons required to work in any space on board the vessel.
- (2) For hazardous work on board a lifeline system shall be provided adequate to ensure the safety of the persons required to undertake such work and constant communication between crew and deck officers should be maintained.
- 3) Skylights, or other similar openings shall be fitted with protective bars not more than 350 millimetres apart and the authority may exempt small openings from compliance with this requirement.
- (4)
 - (a) The surface of all decks shall be so designed or treated as to minimize the possibility of personnel slipping;
 - (b) In particular, decks of working areas, such as in machinery spaces, in galleys, at winches and where fish is handled as well as at the foot and head of ladders and in front of doors, shall be provided with anti-skid surfaces;
 - (c) Crew members working should wear the correct protective gear pertaining to their task and ensure that their gear is maintained eg. Wearing

worn-down boots on non-slip deck will defeat objective; and

(d) All crew members conducting hazardous work should have the necessary qualifications/training to perform such tasks

- (5) Any person on the main deck or on any other exposed deck shall be required to wear an approved buoyancy aid.

141. Safe Access

- (1) Every owner and master shall ensure the provision of safe access to his vessel and on vessels over 30 metres in length, the safe access shall be provided in the form of a gangplank.
- (2) The owner shall ensure that, except in an emergency, access equipment referred to in sub-regulation (1) of this regulation is always used between a secured vessel and any quay, pontoon or similar structure or another vessel alongside to which that vessel is secured, and that:
- (a) the access equipment is placed in position promptly after the vessel has been so secured and remains in position while the vessel is so secured;
- (b) the access equipment which is used is—
- (i) properly constructed, of adequate strength, properly rigged, secured, deployed, and safe to use; and
- (ii) so adjusted from time to time as to maintain safety of access;
- (c) the access equipment and immediate approaches thereto are adequately illuminated;
- (d) when access is necessary between a vessel and the shore and that vessel is not secured alongside, access equipment is provided to

ensure safe access;

- (e) a portable ladder is used as access equipment only where no other safe means of access is practicable;
 - (f) a rope ladder is used as access equipment only between a vessel with high freeboard and a vessel with low freeboard or between a vessel and a boat where no other safe means of access is practicable;
 - (g) a life-buoy with a self-activating light and a separate safety line attached to a quoit or a similar device is provided ready for use at the point of access to a vessel; and
 - (h) an adequate number of safety nets are rigged to safeguard the full length of a gangway or accommodation ladder in use.
- (3) Every owner and master shall ensure that a safe means of access is provided and maintained to any place on a vessel to which a person may be required to go.

142. Deck Openings

- (1)
 - (a) Hinged covers of hatchways, manholes and other openings shall be protected against accidental closing;
 - (b) In particular, heavy covers on escape hatches shall be equipped with counterweights, and so constructed as to be capable of being opened from each side of the cover; and
 - (c) These escape covers shall be painted red and marked in white “EMERGENCY ESCAPE, KEEP CLEAR AT ALL TIMES”
- (2) Dimensions of access hatches shall not be less than 600 millimetres by 600

millimetres or 600 millimetres diameter.

- (3) Where practicable, hand-holds shall be provided above the level of the deck over escape openings.
- (4)
 - (a) Every owner shall ensure that any opening, open hatchway or dangerous edge which is provided with a coaming or sill of less than 600 millimetres in height into, through, or over which a person could fall is fitted with secure guardrails or fencing of adequate design and construction to prevent such occurrence, except where the installation of such guardrails or fencing will interfere with the proper performance of work.
 - (b) The Authority may exempt small openings such as fish scuttles from compliance with this sub-regulation (4)(a)..
- (5) Where a temporary opening is made in a ship for carrying out repair work, the opening shall, as a minimum, be guarded by means of hazard tape displayed at a height of not less than 800 mm and not higher than 1200 mm and at a distance of not less than 2000 mm from the edge of the opening.

143. Bulwarks, Rails and Guards

- (1)
 - (a) Efficient bulwarks or guard rails shall be fitted on all exposed parts of the working deck and on superstructure decks if they are working platforms.
 - (b) The height of bulwarks or guard rails above deck shall be at least 1 metre.
 - (c) Where this height would interfere with the normal operations of the vessel, a lesser height or alternative arrangement may be accepted provided that the authority is satisfied that adequate protection is provided.
- (2) Notwithstanding the minimum freeboard required by Annex 8, the minimum vertical distance from the deepest operating waterline to the lowest point of the top of the bulwark, or to the edge of the working deck if guard rails are

fitted shall ensure adequate protection of the crew from water shipped on deck, taking into account the sea states and the weather conditions in which the vessel may operate, the areas of operation, type of vessel and its method of fishing and shall be to the satisfaction of the Authority.

- (3) (a) If guard rails are fitted, clearance below the lowest course of rails shall not exceed 230 millimetres;
- (b) Other courses shall not be more than 380 millimetres apart, and the distance between stanchions shall not be more than 1.5 metres; and
- (c) In a vessel with rounded gunwales, guard rail supports shall be placed on the flat of the deck. Rails shall be free from sharp points, edges and corners and shall be of adequate strength.
- (4) (a) Means to the satisfaction of the Authority, such as guard rails, lifelines, gangways or underdeck passages, shall be provided to protect the crew in moving between accommodation, machinery and other working spaces; and
- (b) Storm rails shall be fitted as necessary to the outside of all deckhouses and casings to secure safety of passage or work for the crew.
- (5) Stern trawlers shall be provided with suitable protection such as doors, gates or nets at the top of the stern ramp at the same height as the adjacent bulwark or guard rails and when such protection is not in position a chain or other means of protection shall be provided across the ramp.

144. Stairways and Ladders

For the safety of the crew, stairways and ladders of adequate size and strength with handrails and non-slip treads shall be provided to the satisfaction of the Authority.

145. Lifting Appliances, Pulleys and Wire Ropes

- (1) Every employer shall ensure that any vessel's fishing gear and lifting appliances are:
 - (a) (i) of adequate strength for the purpose for which it is used;
 - (ii) free from patent defect;
 - (iii) properly installed or assembled;
 - (iv) properly maintained; and
 - (v) used only in a safe and proper manner;
 - (b) not loaded in excess of its certified safe working load, except for the purpose of carrying out a test referred to in paragraph (d) of this sub-regulation;
 - (c) operated only by a person properly trained in the operation thereof;
 - (d) tested by a competent person after the manufacturing or installation thereof, as the case may be, but before being put into operation, and thereafter after any repairs to or modification of the lifting plant which is likely to alter the safe working load or affect the strength or stability thereof.
- (2) Lifting appliances shall be;
 - (a) tested by a competent person after the manufacturing or installation thereof, as the case may be, but before being put into operation, and thereafter after any repairs to or modification of the lifting plant which is likely to alter the safe working load or affect the strength or stability

thereof but at least every 4 years; tested by a competent person after the manufacturing any of the tests referred to

- (b) provided with a test certificate stating that the lifting appliance was tested by a competent person and specifying the safe working load(s);
 - (c) clearly and conspicuously marked with its safe working load;
 - (d) provided with a diagram or indicator indicating to the operator the safe working load of the lifting plant corresponding to its operating radius, if it has a safe working load which varies according to its operating radius;
 - (e) fitted with a load-attaching device so designed or proportioned that the accidental disconnection of a load under working conditions is prevented;
- (3) No pulley block shall be used in hoisting or lowering unless the safe working load is clearly stamped thereon.
- (4) Means shall be provided to enable any person using chain or wire rope sling to ascertain the safe working load for such chain or sling for the conditions under which it may be used.
- (5) Every wire rope used for trawling, hoisting or lowering shall be inspected by the safety officer or a qualified person every 3 months provided that when any wire has broken in such rope it shall be inspected at least monthly and the inspection of such ropes shall be recorded by the safety officer in the safety log book.
- (6) No wire rope shall be used in trawling, hoisting or lowering if in any length of eight diameters the total number of visible broken wires exceeds ten percent of the total number of wires, or the rope shows sign of excessive wear,

corrosion or other defect which in the opinion of the person inspecting it, renders it unfit for use.

- (7) (a) A thimble or loop splice made in any wire rope shall have at least three tucks with a whole strand of the rope and two tucks with one half of the wires cut out of each strand; and
- (b) The strands in all cases shall be tucked against the lay of the rope, provided that the provisions of this paragraph shall not prevent the use of another form of splice which can be shown to be as effective as that laid down in this paragraph.

146. Safeguarding of Machinery

- (1) Every owner shall;
- (a) specifically cause every exposed and hazardous part of machinery on board a vessel which is within the normal reach of a person to be effectively safeguarded by means of insulation, fencing, screening or guarding so that it does not constitute a further hazard or potential hazard; and visible warning signs stating its dangers.
- (b) ensure that the quality of material used for such insulation, fencing, screening or guarding is suitable for the purpose for which it is being utilised;
- (c) ensure that all insulation, fencing, screening or guarding is properly maintained and kept in position while the guarded part is in operation; and
- (d) supply suitable apparatus to stop immediately any machine on board a vessel in an emergency and in particular, potentially hazardous machinery on deck shall be provided with means of stopping from a local position A secondary emergency stop apparatus should be

installed in the bridge for hazardous machinery eg line-hauler, winch.

- (e) crew members operating machinery should wear the correct protective gear at all times

147. Protection against Noise

- (1) (a) Measures shall be taken to reduce the effects of noise upon personnel in machinery, accommodation and navigation spaces to the levels tabled below as far as is practicable.
- (b) Safety warning signs shall be placed at all entrances to the machinery space advising personnel of high noise levels and hearing protectors shall be provided for personnel entering the space and any other space where noise levels above 85 dB(A) are expected.

| Compartment | Noise limit dB(A) |
|--|-------------------|
| Machinery Spaces - Continuously Manned | 85 |
| Machinery Spaces - Unmanned | 110 |
| Accommodation | 75 |
| Wheelhouse | 65 |

- (2) Owners and masters shall ensure that crew are aware of typical noise levels and the maximum recommended daily noise dose for unprotected ears as tabled in Annex 10.

148. Use of Asbestos

No asbestos based material may be used for lagging or for any purpose on board vessels.

149. Standard Operating Procedures

The owner and master of every vessel shall ensure that Standard Operating Procedures, to the satisfaction of the Authority, are developed and carried on board for any hazardous operation which is required to be carried out by the crew during the operation of the vessel.

CHAPTER VIII CREW ENVIRONMENT

150. Position of Crew Accommodation

- (1) Crew accommodation shall;
 - (a) be situated above the deepest operating load waterline; and,
 - (b) not be situated forward of the collision bulkhead.

151. Height of Crew Accommodation

- (1) The minimum height of the crew accommodation and any other space where the crew may be required to work shall be 2,10 metres.
- (2) The Authority may exempt sleeping rooms, store rooms and sanitary accommodation from the above requirements, but not to less than 2.00 metres of minimum height, at every point in the room which is available for

free movement.

- (3) The Authority may exempt vessels less than 35 metres in length from the requirements of sub-regulations (1) and (2) of this regulation, but not to less than 1,90 metres of minimum height, at every point in the compartment which is available for free movement.

152. Bulkheads and Paneling

- (1) All bulkheads enclosing the crew accommodations or being a boundary of the crew accommodation shall be properly constructed of steel or other suitable material.
- 2) Any bulkhead that has exposed frames or other protrusions that could cause injury during the vessels movement at sea, is to be panelled.
- (3) Any bulkhead which separates any part of the crew accommodation from a fuel tank, cargo or machinery space, a lamp or paint room, a store room (not forming part of the crew accommodation other than a "Dry Provisions" store room), a chain locker or cofferdam shall be gastight and shall be watertight where necessary to protect the crew accommodation.
- (4) Any bulkhead which separates any part of the crew accommodation from sanitary accommodation, laundry, washing rooms or galley shall be watertight to such height as necessary to prevent the passage of water.
- (5) A minimum watertight height of 0,23 metres above the floor of the sanitary accommodation is required.
- (6) Any inside panelling in the crew accommodation shall be constructed of suitable material with a surface which can easily be kept clean.
- (7) Neither bulkhead not panelling shall be constructed in such a manner or of

such material likely to harbour vermin.

153. Overhead Decks

Overhead decks which are exposed to the weather shall be insulated to the satisfaction of the Authority.

154. Flooring

- (1) All decks which form the floors in the crew accommodation shall be fitted with material providing good foothold and be capable of easily being kept clean and the floor covering shall be impervious to water and if the deck is situated on top of an oil tank, impervious to oil.
- (2) The surface of decks which form the floors in crew accommodation, not being floors in sanitary accommodation, galleys, store rooms or laundries shall be covered with a material complying with the following: The material shall;
 - (a) provide adequate foothold, whether wet or dry;
 - (b) be sufficiently hard and strong to withstand all expected conditions of service;
 - (c) adhere closely to the surface upon which it is laid under all conditions of service;
 - (d) provide a warm and comfortable surface;
 - (e) not readily ignite in the position in which it is laid;
 - (f) after being immersed in water for a period of 48 hours, the moisture

content of the material should not exceed 7% of its dry weight; and

- (g) be corrosion resistant.
- (3) (a) The floors of sanitary accommodation, galleys and laundries in the crew accommodation shall be covered with terrazzo, tiles, or other hard material which is impervious to liquids;
- (b) The floor covering shall be properly laid and shall provide a good foothold; and
- (c) The joining of the floors with the side walls shall be rounded in a manner which will avoid crevices.

155. Protection from Weather

- (1) In every ship the crew accommodation and the means of access thereto and egress therefrom shall be so arranged and constructed and situated in such a position as to ensure the:-
- (a) protection of the crew against injury to the greatest practicable extent;
 - (b) protection of the crew accommodation against the weather and the sea;
 - (c) insulation of the crew accommodation from heat and cold;
 - (d) protection of the crew accommodation against moisture due to condensation;
 - (e) exclusion from the crew accommodation of alluvia originating in other spaces in the ship; and
 - (f) exclusion from the crew accommodation, to the greatest practicable extent, of noise originating in other spaces in the ship.

- (2) Without prejudice to the generality of the foregoing paragraph:-
- (a) every opening from an open deck into the crew accommodation shall be protected against the weather and sea;
 - (b) the crew accommodation shall be accessible at all times from the open deck;
 - (c) access to sleeping rooms, mess rooms, recreation rooms and studies forming part of the crew accommodation shall be obtained from a passageway which shall be provided with a hinged door at entrances from the open deck;
 - (d) bow hawse pipes and other pipes containing anchor cables shall not be situated in the crew accommodation;
 - (e) All steam pipes, hot water pipes and calorifiers in or serving the crew accommodation shall be efficiently lagged wherever lagging is necessary for the conservation of heat or the protection of the crew against injury or discomfort and all cold water pipes in the crew accommodation shall be efficiently lagged wherever lagging is necessary for prevention of condensation.
 - (f) Ventilator trunks to cargo spaces or tanks shall be made of steel or other suitable material and shall be gastight where they pass through any part of the crew accommodation.
 - (g) Batteries shall not be placed in any sleeping room provided for the crew, and precaution shall be taken which will ensure that fumes from such batteries cannot discharge into any part of the crew accommodation.
 - (h) The bulkheads and the parts of the ship's side which enclose the crew accommodation shall be insulated in a manner which will prevent overheating of the accommodation and shall be covered with protective covering which will prevent the condensation of moisture.
 - (i) Every bulkhead, casing and deck separating the crew accommodation from other spaces in the ship in which heat or cold may be generated shall be insulated in a manner which will prevent the crew

accommodation being so affected by such heat or cold or by condensation as to prejudice the health or comfort of the crew

- (j) There shall be no direct opening between the crew accommodation (other than recreation deck spaces) and any space used as a store room for engine room stores or deck department stores.
- (k) There shall be no direct opening between the crew accommodation and spaces use as -
 - (i) oil fuel bunkers;
 - (ii) cargo or machinery spaces;
 - (iii) lamp rooms or paint rooms;
 - (iv) store rooms not forming part of the crew accommodation;
 - (v) chain lockers; or
 - (vi) cofferdams.

Provided that there may be a direct opening between machinery spaces and sanitary accommodation and changing rooms provided for the sole use of crew of the engine room department.

- (l) If any part of the crew accommodation is situated on a deck which forms the crown of a space in which oil may be carried in bulk, such deck shall be oiltight.
- (m) No manholes or other openings to the oil tanks shall be situated in the crew accommodation.
- (n) The means of access to and egress from every part of the crew accommodation shall be so situated that in the event of fire in any lamp room or paint room in the ship, access to and egress from the crew accommodation will not be impeded.

156. Heating

- (1) (a) Vessels shall be provided with a permanently installed heating system for all sleeping rooms, mess rooms, recreation rooms, sanitary accommodation and offices forming part of the crew accommodation; and

(b) The heating system shall be capable of ensuring that when the ventilation system is providing at least 0.4 m³ of fresh air per minute for each person whom the space is designed to accommodate at one time and the ambient temperature of the open air is 0 °C, the temperature therein can be maintained at 15 °C for vessels operating between the latitudes of 40°N and 40°S and at 20 °C for vessels operating South of 40°S or North of 40°N.
- (2) The permanent heating system required by sub-regulation (1) of this regulation shall be operated by steam, hot water or electricity or shall be a system supplying warm air.
- (3) The heating equipment shall be so constructed, installed and, if necessary, shielded so as to avoid the risk of fire and not to constitute a source of danger or discomfort to the crew.
- (4) Means shall be provided to vary and switch the supply of heat to any space on or off.

157. Lighting

- (1) (a) In every ship an electrical system shall be installed which is capable of providing adequate lighting in every part of the crew accommodation.

(b) The electric lighting shall be so arranged so as to give the maximum benefit to the crew and in particular an electric reading light, emitting at least 200 lumens shall be fitted at the head of each bunk which can be switched on

and off from the bunk.

- (c) An efficient alternative source of light or source of electrical power shall always be available for emergency lighting of the crew accommodation.

- (2) All enclosed spaces shall be provided with electric lighting of sufficient intensity taking into account the safe use of any particular area and as far as possible it shall be endeavored to ensure that the lighting provided enables a person of normal vision to read an ordinary newspaper in any point in the room. The minimum illumination of spaces shall be as follows:
 - (a) Sleeping rooms and day rooms:
 - (i) 20 lx immediately in front of any drawer, bookcase, clothes locker, wardrobe and toilet mirror;
 - (ii) 50 lx at any wash basin; and
 - (iii) 60 lx at any seat at a writing desk or table.

For the purposes of these spaces, reading lights at the heads of bunks shall not be taken into account in determining the illumination of a space except in the case of a sleeping room provided for one person only.

- (b) Mess rooms:
 - (i) 20 lx at general measurement points; and
 - (ii) 50 lx at any table and sink.

- (c) Offices:
 - (i) 20 lx in front of any drawer or bookcase; and
 - (ii) 80 lx at every writing position at a desk or table.

- (d) Sanitary accommodation:
 - (i) Toilets - 30 lx in way of the pan;
 - (ii) Shower spaces - 20 lx in the centre of the spaces; and
 - (iii) Washrooms and basins:
 - (aa) 30 lx at general measuring points; and
 - (bb) 50 lx at any wash basin and at or near the head of any bath.

- (e) Laundries:
 - (i) 30 lx at any general measuring point; and
 - (ii) 50 lx at any washing trough or washing machine.

- (f) Galleys
60 lx at all working positions. The lamps shall be so positioned so as to maximise the amount of light to food preparation tables, the range top, serving tables and washing up sinks.

- (g) Provision and dry store rooms:
 - (i) 20 lx at general measuring points; and
 - (ii) 20 lx in front of shelving and cupboards.

- (h) Cold rooms
10 lux at general measuring points.
 - (i) Passageways and companionways:
20 lx at general measuring points. A light shall be placed at or near the head of each stairway, ladder or hatchway and at or near any lockers provided for working clothes.

- (j) Factories:
 - (i) 30 lux at general measuring points; and
 - (ii) 60 lx at all working positions.

- (3) The illumination levels required by paragraph (b) shall be measured at a height of 840 mm (or lower in the case of passageways and companionways) above the deck as follows:
 - (a) where general measurement points are prescribed the measurements shall be taken midway between every adjacent lamp and midway between every lamp and the nearest boundary of the space;
 - (b) where a particular measurement point is specified then measurements shall be taken at that point; and

 - (c) provision stores shall be measured when empty.

158. Ventilation

- (1) In every ship the enclosed parts of the crew accommodation and working areas shall be ventilated by a system which will maintain the air therein in a state of purity adequate for the health and comfort of the crew and shall be additional to any side scuttles, skylights, companions, doors or other apertures not intended solely for ventilation.

- (2) (a) Every enclosed space forming part of the crew accommodation or working area being a space not ventilated by a trunked mechanical ventilation system, shall be provided with a forced draught inlet and natural exhaust ventilation which shall be capable of providing an amount of air equal to at least 30 cubic metres per hour per man expected to be accommodated in the compartment.

Provided that in spaces such as galleys and toilets where heat and odours may be dispelled into adjacent spaces, arrangements shall be such as to ensure a slight negative pressure in the space.

- (b) Whatever the number of persons required to use a compartment identified by sub-regulation (2)(a) of this regulation, the total volume of fresh air per minute shall not be required to be such as would result in more than 20 fresh air changes per hour.
 - (c) No ventilator shall be situated directly over a doorway, stairway or exhaust opening.
 - (d) The sectional area of every part of the inlet and exhaust system (other than a part serving only a drying room or locker) shall be such as to ensure that a maximum air flow velocity of 5 metres per second only is possible.
- (3) Vessels over 35 metres in length shall be provided with trunked mechanical ventilation in accordance with Annex 11.
- (4) Power for the system of forced draught or trunked mechanical ventilation system shall be available at all times when any members of the crew are on board.
- (5) Ventilation systems shall be quiet in operation.

159. Drainage

- (1) In every ship efficient drainage by pipes or channels shall be provided for every part of the crew accommodation situated on an open deck wherever such drainage is necessary for clearing water shipped from the sea.
- (2) There shall be no drainage from any source (not being sanitary accommodation) into the sanitary accommodation forming part of the crew accommodation.

- (3) Every space appropriated for use as sanitary accommodation shall be served by one or more scuppers which do not serve any space other than sanitary accommodation.
- (4) The scuppers shall be at least 50 mm in diameter and shall be situated wherever water is likely to collect on the floor of the space.

160. Painting.

- (1) In every ship the interior sides and ceilings of every part of the crew accommodation shall be covered with enamel, paint or other suitable material and the paint or other material shall be of good quality and white or light in colour.
- (2) The wooden parts of the furniture and fittings in the crew accommodation shall be finished externally with paint, varnish, polish or by other suitable means.
- (3) All paint, varnish, polish and other finishes in the crew accommodation shall be capable of being easily kept clean and shall be maintained in good condition.

161. Sleeping Rooms

- (1) Separate sleeping rooms shall be provided, as far as practicable, to ensure that rest periods of watchkeepers are not compromised. In particular;
 - (a) Every watch shall be provided with sleeping rooms separate to those of other watchkeepers; and,
 - (b) Day-men shall be provided with sleeping rooms separate from watchkeepers.

- (2) The authority may permit more than 4 persons to be accommodated in a room, if satisfied, after consultation with the owner of the ship and with such organisation as appears to be representative of the ratings concerned, that the comfort and safety of the ratings is not compromised.
- (3) The minimum floor area provided for each person in a sleeping room forming part of the crew accommodation shall be as follows:-
 - (a) In vessels under 45 metres in length 1.5 m²; and
 - (b) In vessels of 45 metres in length and over 2.0 m²
- (4) In determining the floor area of a room for the purpose of this paragraph, the space occupied by berths and lockers and spaces which by reason of their small size, irregular shape or height cannot accommodate furniture and do not contribute to the area available for free movement, shall not be taken into account.
- (5) Separate sleeping rooms for men and women should be provided.

162. Bunks

- (1) Every vessel proceeding to sea for more than 16 hours shall be provided with a bunk for each person accommodated on the vessel.
- (2)
 - (a) The framework of each bunk, and the leeboards or lee-rails thereof, if any, shall be constructed of metal or other material which is hard and smooth and unlikely to become corroded;
 - (b) The framework shall be so made as not to be likely to harbour vermin;

and

- (c) In particular, if the bunk is constructed with tubular frames, the frames shall be completely sealed and without perforations.
- (3) There shall be unobstructed access to at least one side of each bunk and in particular, if the adjacent sides of two beds in the same room are parallel to each other or when projected make an angle of less than 90° with each other, the mean distance between those sides at any point shall not be less than 760 mm if both bunks are in single tier or 900 mm in any other case.
- (4) (a) Where bunks abut upon each other they shall be separated by partitions made of wood or other suitable material; and
- (b) Where bunks are adjacent to each other a division from the bottom of the bunk to the deck head or underside of the next bunk shall be provided.
- (5) No bunk shall be placed:-
- (a) within 100 mm of the outlet of a ventilation trunk which may be used for circulating hot or cold air; or
 - (b) within 50 mm of a bulkhead or the ship's side, unless the bed is so supported and the room so constructed as to avoid harbouring dirt and vermin in or near the bed, to enable the bedding to be kept clean and dry, and to minimise the soiling of paintwork in way of the bunk.
- (6) Practical bunks shall not be arranged in tiers of more than two.
- (7) No bunk shall be less than 300 mm from the floor of the room measured from the bottom of the mattress.
- (8) The upper bunk in a double tier shall be at least 760 mm below the lower side of the deck head beams or other obstructions measured from the bottom of the mattress and the bottom of the mattress in the lower bed shall be at least 760 mm below the bottom of the mattress in the upper bunk.

- (9) Subject to the provisions of sub-regulation (8) of this regulation, the mean size of the bunks provided for the crew shall be at least 1900 mm by 800 mm, the measurements being taken inside the lee-boards or lee-rails, if any, and at right angles to each other.
- (10) (a) Every bunk provided for a member of the crew shall be fitted with a mattress made of material which will resist damp and is unlikely to harbour vermin.
- (b) A bottom of wood, canvas or other dustproof material shall be fitted to every bunk which is fitted above another bunk.

163. Furniture and Fittings

- (1) Every sleeping room shall be provided with at least the following equipment:
- (a) for each person accommodated in the room:
- (i) 1 drawer of capacity 0.06 m³;
 - (ii) 1 clothes locker or wardrobe at least 1.7m high and 50 cm² in internal sectional area; and
 - (iii) 1 coat hook in addition to any coat hooks fitted in a locker or wardrobe.
- (b) A table of fixed or drop-leaf type, or a desk, or a sliding leaf or top fitted to a chest of drawers;
- (c) Comfortable seats sufficient to accommodate 50% of the persons accommodated in the room at one time;
- (d) A mirror suitable for toilet purposes;

- (e) A book rack; and
 - (f) A curtain, fitted to each bunk to provide the crew member with privacy and to prevent the ingress of light from the room provided that if the room contains only one bunk a curtain is not required.
- (2) (a) All lockers, wardrobes, tables, desks, the unupholstered parts of chairs and settees and similar furnishings shall be made of polished hardboard, rustproof metal or other smooth and impervious material not likely to crack, warp or become corroded; and
 - (b) All furniture provided in sleeping rooms shall be so made as not to be likely to harbour vermin.
- (3) In every sleeping room every drawer, locker and wardrobe shall be lockable.
 - (4) All materials used for the construction of furniture and fittings shall be so constructed that there are no sharp edges or sharp protrusions.

164. Mess Rooms

- (1) Every vessel required to carry a certificated cook shall be provided with a mess room with seating and eating facilities capable of accommodating at least 75% of the crew at any one time.
- (2) Mess rooms should be as close as is practicable to the galley.

165. Furniture and Fittings in Mess Rooms

- (1) Every mess room shall be provided with sufficient seating and tables to allow a space of at least 500 mm per person, measured along the edge of the table for each person required to use the room and tables shall be at least 600 mm

wide if seats are provided on both sides of the table and 380 mm wide if seats are provided on one side only.

- (2) All tables, lockers chairs and other fittings shall be made of polished hardboard, rustproof metal or other smooth and impervious material not likely to crack, warp or become corroded or be likely to harbour vermin.

166. Recreation Rooms

- (1) In every vessel of 45 metres in length and over recreation room(s) shall be provided and the room(s) shall be capable of accommodating at least one third of the persons carried on board and shall be provided with tables, chairs and a bookcase.
- (2) Vessels under 75 metres in length may be exempted from the requirements of sub-regulation(1) of this regulation if mess rooms are provided which are capable of accommodating all of the crew and are fitted with book cases.

167. Sanitary Facilities

- (1) The following facilities shall be provided as a minimum:
 - (a) One bath or shower for every 4 persons or part thereof;
 - (b) wash basin for every 4 persons or part thereof;
 - (c) one mirror suitable for toilet purposes for every 6 persons or part thereof; and
 - (d) one toilet for every 4 persons or part thereof,

Provided that not less than two of each item listed above shall be provided.

- (2) The sanitary facilities shall be situated as close to the sleeping

accommodation of the persons for whose use it is appropriated as is practicable.

- (3) (a) In every ship, adequately ventilated compartments or lockers shall be provided for hanging oilskins and protective clothing used by the crew;
 - (b) The compartments or lockers shall be situated outside the sleeping rooms of the crew and in a position readily accessible therefrom; and
 - (c) Vessels greater than 35 metres in length shall be provided with changing rooms for this purpose to the satisfaction of the authority.
- (4) Sanitary facilities provided adjacent to engine rooms, factory and other working spaces shall not be included in the facilities required by sub-regulation (1) of this regulation unless their positions comply with sub-regulation (2) of this regulation.
 - (5) Every bath, shower and basin shall be provided with hot and cold water and an efficient drainage system.
 - (6) A minimum of 20 litres of potable water per person per day shall be provided for washing purposes.
 - (7) Sanitary facilities shall be maintained in a clean and operable condition at all times.

168. Supply of Drinking Water

- (1) In every ship, a dedicated supply of at least 2.5 litres of drinking water per person per day shall be provided for drinking and cooking purposes.
- (2) Fresh drinking water shall at least be laid on to taps in the galleys and mess rooms.

169. Laundry Facilities

Suitable laundry and drying facilities shall be providing taking in account the number of crew and intended operation and voyage duration of the vessel.

170. Galleys

- (1) Every ship shall be provided with a galley for the preparation of food for the crew, which shall be situated as near as practicable to the mess room(s) and any necessary equipment shall be provided to enable food to be served hot in the mess rooms under all weather conditions.
- (2) There shall be no direct opening between the galley and any sleeping room.
- (3) Any galley situated on an open deck shall be provided with weather doors which are horizontally divided into halves, so that the upper half can be opened independently of the lower half, if such a division is necessary for the lighting, ventilation or privacy of the galley or for the service of food therefrom.
- (4) Every galley shall so far as is reasonable and practicable, be lighted by natural lighting from all the sides and from overhead.
- (5) Every galley shall be provided with at least three fixed points for artificial lighting, one of which shall be situated close to a cooking range required by this regulation.
- (6) If the galley is situated on an open deck, openings shall be cut in the sides and ends of the galley for ventilation purposes and shall be fitted with dust-tight shutters made of steel or other suitable material and permanently attached to the structure of the galley.
- (7) Every galley shall be provided with exhaust fans which will draw oil fumes

from the cooking appliances therein and discharge the fumes into the open air unless the Authority is satisfied that the fumes can only discharge into the open air.

- (8) The exhaust fan is to be fitted with an emergency stop switch located outside of the galley.
- (9) The exhaust fan shall be fitted with a grease trap which shall be accessible and easy to remove for cleaning purposes.
- (10) The floor of the galley shall be provided with gutters and with scuppers which shall be led overboard or to an enclosed tank served by a mechanical operated suction pump and the position and number of the gutters and scuppers shall be such as will ensure the efficient drainage of the floor.
- (11) The cooking appliances in the galley shall be arranged in a manner which will facilitate the cleaning of the galley.
- (12)
 - (a) All cupboards and dressers in the galley shall be made of material which is impervious to dirt and moisture and can easily be kept clean;
 - (b) All metal parts of the cupboards and dressers shall be rustproof;
 - (c) The cupboards and dressers shall be so made as not to be likely to harbour dirt or vermin; and
 - (d) The bottoms of all cupboards and dressers in the galley shall either be flush with the deck or shall be so fitted as to enable the deck space beneath them to be readily accessible for cleaning.
- (13) Every galley shall be provided with such equipment as will enable food in sufficient quantity to be properly and readily prepared for the persons whom the galley is intended to serve, and the cooking utensils to be hygienically cleaned.
- (14)
 - (a) Salt water taps shall not be fitted over a sink in any galley or other

place in which food may be prepared for the crew;

- (b) Hot and cold fresh water shall be laid on to a sink in the galley for washing-up purposes; and
- (c) A connection shall be provided on a water pipe within the galley, and shall be suitable for the connection of a hose with which the floor may be scoured.

- (15) Galley facilities shall be maintained in a clean and operable condition at all times.

171. Dry Provision Store Rooms

- (1) In every ship, one or more store rooms shall be provided for the storage of dry provisions for the crew and such rooms shall be fitted with sufficient shelves, cupboards and bins having regard to the maximum period likely to elapse between successive replenishments of stores and to the maximum number of persons for whom food is to be served.
- (2) Every dry provision store room shall be enclosed by bulkheads constructed of steel or other suitable material.
- (3) Access to every dry provision store room shall be obtained from a passageway, galley, pantry or another store room, or from a position on an open deck which, in so far as is reasonable and practicable in the circumstances, shall be a protected position.
- (4) Every dry provision store room shall be so situated, constructed and ventilated as to avoid deterioration of the stores through heat, draught, condensation or infestation by insects or vermin.
- (5) No part of the dry provision store room shall be used for the storage of bedding or textiles.

172. Cold Store Rooms and Refrigerating Equipment

- (1) In every ship refrigerating equipment and cold store rooms shall be provided and shall be, having regard to the period likely to elapse between successive replenishments of stores, adequate for the storage of perishable provisions for the crew.
- (2) Access to every cold store room shall be obtained from a passageway, galley or pantry or from another store room.
- (3) Refrigerating machines shall of sound construction and of proven design.
- (4) Every exposed pipe which may contain toxic or inflammable gas shall be adequately protected from damage.
- (5) All walk-in refrigerated chambers shall be fitted with audible and visual lock-in alarms.

173. Hospitals

- (1) Every vessel which is 35 metres in length or over and every vessel which is less than 35 metres in length but proceeds more than 200 miles offshore with a crew of 15 or more persons shall be provided with a space appropriated for use as a temporary hospital for the crew. When the room is in use as a hospital it shall be used for no purpose other than the treatment of sick persons.
- (2) Alternative accommodation shall be provided for crewman normally accommodated in the temporary hospital when the hospital is in use and this alternative accommodation shall at least consist of a bunk located in a sleeping room of the dimensions specified in Regulation 162(9), however the Authority may allow a relaxation of the standards specified in regulations 161162 & 163 for this alternative accommodation.

- (3) The hospital shall be readily accessible and so situated that it is readily accessible from the sleeping accommodation of the master or a person designated by the master to take charge of the patient(s).
- (4) Sick persons shall have ready access to bath or shower, wash basin, mirror and toilet from the hospital.
- (5) Hospitals shall be adequately ventilated and heated to the satisfaction of the Authority.
- (6) At least one single tier bed per 50 crew carried shall be provided in the hospital.

174. Medical Cabinet

- (1) A medical cabinet shall be provided and fitted in a position in which it will remain dry and which is remote from all sources of heat.
- (2) The medical cabinet shall be of a size, design and construction suitable for storing the medicines, medical stores and book of instruction required by the Regulations.
- (3) The medical cabinet shall be lighted by an electric light which shall be inside or immediately outside the cabinet, and which will enable all the contents of the cabinet to be clearly seen in the absence of light from any other source.
- (4) The medical cabinet and the place in which it is fitted shall be so ventilated as to avoid deterioration of the contents of the cabinet.
- (5) Portable medical cabinets may be provided, as a substitute for the medical cabinet, if the volume of medical supplies required to be carried render it practicable.
- (6) Medical cabinets shall be lockable

- (7) The medical cabinet shall be inspected at least once a year by a competent person and a certificate issued stating that the contents of the cabinet are sufficient for the type of operation and voyages the vessel is engaged in.

175. General

- (1) Alleyways in crew accommodation should be not less than 700mm wide and be fitted with handrails on at least one side.
- (iii) Access to ordinary exits and emergency exits should be marked with direction indicators. Exits should be marked in a conspicuous manner.

176. *Maintenance and Inspection of Crew accommodation*

- (1) (a) The crew accommodation shall be maintained in a clean and habitable condition and all equipment and installations shall be maintained in good working order.
- (b) Every part of the accommodation (not being a store room) shall be kept free of stores and other property not belonging to or provided for the use of persons for whom that part of the accommodation is appropriated.
- (2) The master of the ship or an officer appointed by him for the purpose shall inspect every part of the crew accommodation at intervals not exceeding ten days, and shall be accompanied on the inspection by one or more members of the crew. The master of the ship shall cause to be entered in the ship's official logbook a record of: -
- (a) the time and date of the inspection;
- (b) the names and ranks of the persons making the inspection and
- (c) particulars of any respects in which the crew accommodation or any part thereof was found by any of the persons making the inspection not

to comply with these Regulations and measures taken by the master to ensure compliance.

177. Inspection by the Authority

- (1) The owner shall cause the Authority to inspect the crew accommodation in every ship or cause it to be inspected whenever -
 - (a) the ship is registered or re-registered in the Republic;
 - (b) any part of the crew accommodation in the ship undergoes substantial alterations or repairs and
 - (c) the number of persons accommodated in any sleeping room is increased above that allowed in accordance with regulation 157.

- (2) The Authority may also inspect the crew accommodation at any time if there is reason to believe (whether or not in consequence of a complaint) that any of the provisions of these Regulations have been contravened in respect of that ship, or that any condition subject to which the Authority has exempted the ship from a requirement of these Regulations has not been satisfied.

CHAPTER IX

SHIPBORNE NAVIGATIONAL EQUIPMENT AND ARRANGEMENTS

178. Compasses

- (1) Vessels of 45 metres in length and over shall be fitted with:
 - (a) a standard magnetic compass in a suitable binnacle positioned on the vessels centreline, to the satisfaction of the Authority;
 - (b) a second magnetic compass in a binnacle adjacent to the main and secondary steering positions for the helmsman to steerby, however, where a projected or reflected image of the standard compass required by paragraph (a) of this sub-regulation is provided for this purpose the second magnetic compass shall be fitted in a suitable position to the satisfaction of the Authority and
 - (c) Electromagnetic Compatibility with electronic equipment within 1 metre radius of the compass should be considered utilizing the manufacturers' specifications.

- (2) Vessels of less than 45 metres in length shall be fitted with:
 - (a) a standard magnetic compass in a suitable binnacle positioned on the vessels centreline with a projected or reflected image provided adjacent to the main and secondary steering positions for the helmsman to steer by. The installation shall be fitted to the satisfaction of the Authority; and
 - (b) a second magnetic compass in a binnacle adjacent to the main steering position, where a projected or reflected image of the standard compass is not provided for the helmsman to steer by.
 - (c) Electromagnetic Compatibility with electronic equipment within 1 metre radius of the compass should be considered utilizing the manufacturers'

specifications.

- (3) A gyro-compass, to the satisfaction of the Authority, shall be fitted:
 - (a) in vessels of 75 metres in length and over;
 - (b) in vessels intended for operation in latitudes where the horizontal component of the earth's total magnetic force is insufficient to provide adequate directional stability to the magnetic compass. The master gyro-compass or a gyro-repeater shall be clearly readable by the helmsman at the main steering position. A gyro-repeater(s) shall be fitted for taking of bearings to the satisfaction of the Authority and
 - (c) The gyro compass required by paragraphs (a) and (b) of this sub-regulation shall be so positioned that it can be read by the helmsman, either directly or from a repeater at the main steering position, and shall be fitted with a repeater or repeaters for taking bearings to the satisfaction of the Authority.
- (4) Where a gyro-compass is fitted which can be read by the helmsman either directly or from a repeater at the main steering position, the second magnetic compass referred to in sub-regulations (1)(b) and (2)(b) of this regulation need not be fitted, provided that the projected or reflected image of the standard magnetic compass is available for the helmsman to steer by.
- (5) Resources shall be provided to enable compass bearings to be taken by day and night and where the compass referred to in sub-regulation (2) of this regulation is fitted such that bearings cannot be taken by the main steering compass, a handheld compass shall be provided.
- (6) (a) Each magnetic compass referred to in sub-regulation (2) of this regulation shall be properly adjusted at intervals not exceeding 12 months and its table or curve of residual deviations shall be available at all times and this period may be extended at the discretion of a surveyor on condition that an appropriate and up to date deviation record book is

maintained and the compass deviation is not greater than 10°.

- (b) Each magnetic compass referred to in sub-regulation (1) of this regulation shall be properly adjusted when repairs are carried out to the vessel such that these repairs could affect the residual deviations of the vessel.
- (7) Where a transmitting magnetic compass and repeater is fitted it shall be provided with an emergency electrical supply to the satisfaction of the Authority.
- (8) Illumination and facilities for dimming shall be provided to enable reading of the compass card at all times and if illumination is provided by the vessels main electrical supply, emergency illumination shall be available.
- (9) Where only one magnetic compass is carried, a spare magnetic compass which is interchangeable with the magnetic compass shall be carried.
- (10) Means of communication between the standard compass position and the normal navigation control position and the emergency steering position shall be provided to the satisfaction of the Authority.

179. Depth Sounding Equipment

Vessels shall be fitted with at least one echo sounder.

180. Global Positioning Systems

- (1) All vessels shall carry: –

- (a) an efficient time keeping apparatus and at least one efficient sextant to assist in making accurate celestial observations.
 - (b) at least one global positioning system.
- (2) Vessels may carry two global positioning systems operating off independent power supplies in lieu of the requirements of sub-regulation (1) (a) of this regulation.
- (3) The Global Position Systems should provide means of interfacing with other navigational electronic equipment, as required.

181. Vessel Manoeuvring Data

- (1) The master and owner of every vessel shall cause to be displayed in the wheelhouse for the guidance of the master, a notice which shall indicate the following:
- (a) Speeds of the vessel through the water at least 3 different engine speeds or pitch values equivalent to slow, half and full speeds ahead; and
 - (b) The time elapsed and distance of forward travel of the vessel from the time that full astern power is applied to the vessel whilst moving at full speed ahead until the vessel has stopped in the water.

182. Radar and AIS requirements.

- (1) All vessels shall be fitted with marine radar capable of being interfaced with AIS, to the satisfaction of the Authority.
- (2) Vessels 500 GT and over, an AIS, interfaced with the radar requirements, in

compliance with IMO specifications.

- (3) Vessels <500 GT, an AIS interfaced with the required radar in compliance with 2010 Marine Notice Number, (MARPA and AIS PERFORMANCE SPECIFICATIONS).
- (4) Interfacing with a Global Positioning System shall be provided.

183. Speed and Distance Indicator

Vessels over 75 metres in length shall be fitted with a suitable instrument for measuring speed and distance through the water.

184. Nautical and Other Publications and Documentation

- (1) Adequate and up to date nautical publications are to be carried on board in accordance with the following list for the intended voyage:
 - (a) Charts;
 - (b) Sailing directions (SAN or Admiralty);
 - (c) List of lights;
 - (d) List of radio signals;
 - (e) Tide tables;
 - (f) Relevant Notices to Mariners; and
 - (g) International code of signals (For vessels operating beyond the SA EEZ).
- (2) In addition to the above the following -

- (a) Official Log Book;
- (b) articles of Agreement;
- (c) Standard Operating Procedures for the safe operation of the vessel;
- (d) Company standing orders for the Master and Chief Engineer;
- (e) Maritime Occupational Safety Regulations;
- (f) Code of Safe Working Practices for Fisherman;
- (g) Ship Captain's Medical Guide;
- (h) The Merchant Shipping (Collision) Regulations;
- (i) Approved Stability Book;
- (j) Approved SOPEP manual;(For vessels over 400 GT)
- (k) Oil Record Book; (For vessels over 400GT)
- (l) Garbage Record Book;
- (m) Maneuvering Data Sheet to be displayed in the Wheelhouse
- (n) A copy of these Regulations;
- (o) Relevant S.A. Marine Notices; and
- (p) Documentation required by Merchant Shipping Radio Installation Regulations, 2002, as amended.

185. Signaling Equipment

- (1) A daylight portable signaling lamp shall be provided, the operation of which is not solely dependent upon the main source of electrical power. The power supply shall in any case include a portable battery.
- (2) Vessels shall carry at least the following flags; B, C, G, H, N, Q, V and Wand

vessels operating beyond the SA EEZ shall carry a full set of flags and pennants to enable communications to be sent using the International Code of Signals in force.

186. Navigating Bridge Visibility

- (1) For vessels of less than 45 metres in length, the view of the sea surface shall, under all conditions of trim and deck cargo;
 - (a) be visible no more than 90 metres ahead from the conning position; and,
 - (b) take in an arc from forward of the bow to at least 10 degrees on either side.
- (2) Vessels of 45 metres in length and over, shall comply with sub-regulation (1) of this regulation provided that the sea surface shall be visible no more than 2 ship lengths or 500 metres, whichever is less, ahead from the conning position.
- (3) The horizontal field of vision from the conning position shall extend over an arc of not less than 225 degrees; that is from right ahead to not less than 22.5 degrees behind the beam on either side of the vessel.
- (4) Fishing gear or other obstructions outside the wheelhouse forward of the beam which obstructs the visible view of sea surface from the conning position and create blind sectors in the horizontal field of vision shall meet the following requirements:
 - (a) No single blind sector shall be greater than an arc of 10 degrees;
 - (b) the total arc of blind sectors shall not exceed 20 degrees;
 - (c) the clear sectors between blind sectors shall be at least 5 degrees; and,

- (d) in the view described in sub-regulations (1) and (2) of this regulation each individual blind sector shall not exceed 5 degrees;
- (5) Observers on each bridge wing shall have a horizontal field of vision of at least 225 degrees extending from at least 45 degrees on the opposite bow through right ahead to right astern through 180 degrees on the same side of the vessel.
- (6) The main steering position shall have a horizontal field of vision extending over an arc from right ahead to at least 60 degrees on each side of the vessel.
- (7) The vessels side shall be visible from the bridge wing.
- (8) The height between the lower edge of the wheelhouse front windows and the bridge deck shall be kept as low as possible and in no case shall the lower edge present an obstruction to the forward view.
- (9) The upper edge of the navigating bridge front windows shall allow a forward view of the horizon for a person with a height of eye of 1,800 millimetres above the bridge deck at the conning position when the vessel is pitching in heavy seas.
- (10) Windows shall meet the following requirements;
- (a) Framing between navigating bridge windows shall be kept to a minimum and not be installed immediately forward of any workstation;
 - (b) to help avoid reflections, the bridge front windows should be inclined from the vertical plane top out, at an angle of not less than 10 degrees and not more than 25 degrees;
 - (c) polarized and tinted windows shall not be fitted;
 - (d) a system of ensuring a clear view through at least two wheelhouse

- windows in all weather and sea conditions shall be provided and
- (e) in wheelhouses where the lookout cannot be posted outside, means shall be provided such that at least two windows can be kept clear.

CHAPTER X

LIFE-SAVING APPLIANCES AND ARRANGEMENTS

PART A - GENERAL

187. Evaluation, Testing and Approval of Radio Life-Saving appliances, Life-saving Appliance and Arrangements

- (1) Radio Life-Saving appliances ; Life-saving appliances and arrangements required by this Chapter and the Merchant Shipping Radio Installation Regulations, 2002, as amended, shall be approved by the Authority provided that:
- (a) the appliance or arrangement is in accordance with a specification contained in these Regulations or in a Marine Notice published by the Authority which may be updated from time to time; or,
- (b) the appliance or arrangement has been approved by an organisation recognised by the Authority.
- (2) Novel life-saving appliances or arrangements may be approved by the Authority if the Authority is satisfied that the appliance or arrangement provides an acceptable standard of safety for the envisaged application.
- (3) Radio Life Saving appliances , Life-saving appliances and arrangements shall not be used on vessels unless they have been approved by the Authority.

PART B - VESSEL REQUIREMENTS

188. Number and Types of Survival Craft and Rescue Boats

- (1) Every vessel shall be provided with at least two survival craft.
- (2) The number, capacity and type of survival craft and rescue boats of vessels of 75 metres in length and over shall comply with the following:
 - (a) Survival craft of sufficient aggregate capacity to accommodate on each side of the vessel at least the total number of persons on board shall be provided. In addition, float-free liferafts of sufficient capacity to accommodate at least 100% of the persons on board shall be provided; and
 - (b) a rescue boat shall be provided unless the vessel is provided with a lifeboat which fulfils the requirements of a rescue boat and which is capable of being recovered after a rescue operation.
- (3) Vessels of less than 85 metres in length shall be provided with:
 - (a) survival craft of sufficient aggregate capacity to accommodate on each side of the vessel at least 100% of the total number of persons on board; and
 - (b) a rescue boat, unless the vessel is provided with a survival craft which fulfils the requirement for a rescue boat and can be recovered after a rescue operation.
- (4) In lieu of meeting the requirements of sub-regulations (2)(a) or (3)(a) of this regulation, vessels may carry one or more lifeboats capable of being free-fall launched over the stern of the vessel of sufficient capacity to accommodate the total number of persons on board and with liferafts of sufficient capacity to accommodate the total number of persons on board.

- (5) In lieu of meeting the requirements of sub-regulation (3)(a) of this regulation, vessels of less than 85 metres may carry :-
- (a) float free liferafts of sufficient capacity to accommodate at least 100% of the persons on board;and
 - (b) unless the liferafts required in sub-regulation 5(a) of this regulation are stowed in a position providing for easy side-to side transfer at a single open deck level, additional liferafts shall be provided so that the total capacity on either side is 150% of the total capacity.
- (6) Fully enclosed lifeboats of sufficient aggregate capacity to accommodate on each side of the vessel at least 100% of the total number of persons on board shall be provided for vessels operating South of 60oS or North of 60°N.
- (7) The number of lifeboats and rescue boats that are carried on vessels shall be sufficient to ensure that in providing for the abandonment by the total number of persons on board not more than nine liferafts need be marshalled by each lifeboat or rescue boat.
- (8) The capacity of a single liferaft shall not be for more than 25 persons.

189. Availability and Stowage of Survival Craft and Rescue Boats

- (1) Survival craft shall:
- (a) (i) be readily available in case of emergency;
 - (ii) be capable of being launched safely and rapidly; and
 - (iii) be capable of rapid recovery if also fulfilling the requirements for a rescue boat;
- (b) be so stowed that:

- (i) the marshalling of persons at the embarkation deck is not impeded;
 - (ii) their prompt handling is not impeded;
 - (iii) embarkation can be effected rapidly and in good order; and
 - (iv) the operation of any other survival craft is not interfered with.
- (2) Where the distance from the embarkation deck to the waterline of the vessel in the lightest operating condition exceeds 4.5 metres, survival craft, except float-free liferafts, shall be capable of being davit-launched with a full complement of persons or be provided with equivalent approved means of embarkation.
- (3) Survival craft and launching appliances shall be in working order and available for immediate use before the vessel leaves port and kept so at all times when at sea.
- (4) (a) Survival craft shall be stowed to the satisfaction of the Authority;
- (b) Every lifeboat shall be attached to a separate set of davits or approved launching appliance;
- (c) Survival craft shall be positioned as close to accommodation and service spaces as possible, stowed in suitable positions to ensure safe launching, with particular regard to clearance from the propeller.
- (d) Lifeboats for lowering down the vessel's side shall be stowed with regard to steeply overhanging portions of the hull, so ensuring, as far as practicable, that they can be launched down the straight side of the vessel.
- (e) If positioned forward, lifeboats for lowering down the vessel's side shall be stowed abaft the collision bulkhead in a sheltered position and in this respect the Authority shall give special consideration to the strength of the davits;

- (f) The method of launching and recovering of rescue boats shall be approved, by the Authority, taking into account the weight of the rescue boat including its equipment and 50% of the number of persons it is certificated to carry, the construction and size of the rescue boat and its position of stowage above the waterline in the vessel's lightest operating condition;
- (g) Launching and embarkation appliances shall be approved by the Authority; and
- (h)
 - (i) Liferafts shall be so stowed as to be readily available in case of emergency in such a manner as to permit them to float free from their stowage, inflate and break free from the vessel in the event of its sinking. However, davit-launched liferafts need be not float free;and
 - (ii) lashing, if used, shall be fitted with an automatic (hydrostatic) release system of an approved type.

190. Embarkation into survival craft

- (1) Suitable arrangements shall be made for embarkation into the survival craft which shall include;
 - (a) at least one ladder, or other approved means, on each side of vessel to afford access to the survival craft when waterborne when the vertical distance is in excess of two metres;
 - (b) means for illuminating the stowage position of survival craft and their launching appliances during preparation for and the process of launching, and also for illuminating the water into which the survival craft are launched until the process of launching is completed, the power for which is to be supplied from the emergency source required by regulation 87;
 - (c) arrangements for warning all persons on board that the vessel is about

to be abandoned; and

- (d) means for preventing any discharge of water into the survival craft.

191. Life Jackets

- (1) For every person on board, a "SOLAS TYPE" life jacket approved by the SABS and the Authority shall be carried.
- (2) Life jackets shall be so placed in suitable lockers at the survival craft embarkation points. Lockers shall be readily accessible and their position shall be plainly indicated to the satisfaction of the Authority.
- (3) Each life jacket shall be marked with the official number or name of the vessel on which it is carried.
- (4) Each life jacket shall be fitted with a light complying with the requirements of 2.2.3 and a whistle complying to 2.2.1.7 of the International Life-saving Appliance Code (LSA Code) as published by IMO.

192. Immersion Suits and Thermal Protective Aids

- (1) An approved immersion suit of an appropriate size shall be provided for every person assigned to crew the rescue boat.
- (2) Vessels complying with the requirements of regulations 188(2) and 188(3) and operating South of 40°S shall carry immersion suits for every person on board not accommodated in:
 - (a) lifeboats;

- (b) davit-launched liferafts; or
 - (c) liferafts served by equivalent approved appliances which do not require entry into the water to board the liferaft.
- (3) In addition to sub-regulation (2)(a) of this regulation, vessels operating South of 40 °S shall carry for each lifeboat at least 3 immersion suits of an approved type.
- (4) Vessels operating South of Latitude 40° South shall be provided with sufficient thermal protective aids, of an approved type, for all other persons not required to be provided with immersion suits.

193. Lifebuoys

- (1) At least the following number of lifebuoys, of an approved type, shall be provided:
- (a) 8 lifebuoys in vessels of 85 metres in length and over; and
 - (b) 6 lifebuoys in vessels of less than 85 metres in length.
- (2) At least half of the number of lifebuoys referred to in sub-regulation (1) of this regulation shall be provided with self-igniting lights, of an approved type.
- (3) At least two of the lifebuoys provided with self-igniting lights in accordance with sub-regulation (2) of this regulation shall be provided with self-activating smoke signal, of an approved type, which shall be capable of quick release from the navigating bridge.
- (4) At least one life buoy on each side of the vessel shall be fitted with buoyant lifeline, of an approved type, equal to the length of not less than twice the height at which it is stowed above the waterline in the lightest seagoing

condition, or 30 metres, whichever is greater and such lifebuoys shall not have self-igniting lights.

- (5) All lifebuoys shall be so placed as to be readily accessible to the persons on board and shall always be capable of being rapidly cast loose and shall not be permanently secured in any way.

194. Line Throwing Appliances

Every vessel shall carry a line-throwing appliance of an approved type.

195. Distress Signals

- (1) Every vessel shall be provided, to the satisfaction of the Authority, with means of making effective distress signals by day and by night, including at least 12 rocket parachute flares.
- (2) Distress signals required by this Chapter shall be of an approved type and shall be so placed as to be readily accessible and their position shall be plainly indicated.
- (3) All distress signals shall be kept in a waterproof container.

196. Retro-reflective Materials on Life-saving Appliances

All survival craft, rescue boats, life jackets and lifebuoys shall be fitted with retro-reflective material to the satisfaction of the Authority.

197. Operational Readiness, Maintenance and Inspections

- (1) Before the vessel leaves port and at all times during the voyage, all life-saving appliances shall be maintained in working order and ready for immediate use.
- (2) Instructions for on-board maintenance of life-saving appliances shall be provided and maintenance shall be carried out accordingly.
- (3) Falls used in launching shall be turned end for end at intervals not exceeding 30 months and shall be renewed every 5 years or when necessary due to deterioration, whichever is the earlier.
- (4) Spares and repair equipment shall be provided for life-saving appliances and their components which are subject to excessive wear or consumption and need to be replaced regularly.
- (5) On a weekly basis;
 - (a) all survival craft, rescue boats and launching appliances shall be visually inspected to ensure that they are ready for use;
 - (b) all engines in lifeboats and rescue boats shall be run ahead and astern for a period of not less than 3 minutes provided that the ambient temperature is above the minimum temperature required for starting the engine(s); and,
 - (c) the general alarm system shall be tested.A report shall be made in the official log book and safety officers record book confirming that the inspection and trials have been carried out.
- (6)
 - (a) Inspection of the life-saving appliances, including lifeboat equipment, shall be carried out monthly, by the safety officer, using a checklist to ensure that they are complete and in good order.
 - (b) A report of the inspection shall be entered in the Official log book and

Safety Officers record book.

(c) Emergency repairs of rescue boats may be carried out on board, however, permanent repairs shall be effected by an approved servicing agent.

198. Servicing of Life-saving Appliances

- (1) Every inflatable liferaft, rescue boat and life jacket shall be serviced at intervals not exceeding 12 months at an approved servicing station.
- (2) Disposable hydrostatic release units shall be replaced when their date of expiry has passed. If not disposable, hydrostatic release units shall be serviced at intervals not exceeding 12 months at an approved servicing station.

CHAPTER XI

EMERGENCY PROCEDURES, MUSTERS AND DRILLS

199. Muster List and Abandon Ship Procedure

- (1) A muster list shall be drawn up when the vessel leaves port and shall include the following information
 - (a) duties assigned to different members of the crew in the event of an emergency in connection with:
 - (i) closing of watertight doors, fire doors, valves, scuppers, overboard chutes, side scuttles, skylights, portholes and other similar openings in the vessel;
 - (ii) equipping the survival craft (including portable radio apparatus for the survival craft);
 - (iii) preparation and launching of survival craft;
 - (iv) general preparation of other life-saving appliances;
 - (v) the manning of fire parties assigned to deal with fires; and
 - (vi) the special duties assigned in respect of the operation of fire equipment and installations and
 - (b) the signals for summoning the crew to their survival craft and fire stations and particulars of those signals including the emergency signal for summoning the crew to muster stations which shall be a succession of seven or more short blasts followed by one long blast on the whistle or siren.
- (2) Copies of the muster list shall be posted up in the wheelhouse, engine room and in the crew accommodation.

100. Practice Musters and Drills

- (1) The master shall ensure that all crew are:
 - (a) competent to don a life jacket,
 - (b) aware of the procedures to be followed when abandoning ship;
 - (c) familiar with the fire fighting facilities on board and actions to be taken in the event of a fire;
 - (d) advised of general safety practices on board;
 - (e) have completed a pre-sea familiarisation approved by the Authority;
and
 - (f) be in possession of a valid medical certificate issued by a competent doctor approved by the Authority

In particular the master shall ensure that new members joining the vessel are familiarised with the above preferably before sailing but at least within 24 hours of the vessel leaving port.

- (2) The master shall ensure that a muster of the crew for fire and abandon ship drills is carried out at intervals of not more than 14 days when at sea, provided that these drills shall take place within 24 hours whenever 25 per cent of the crew has been replaced since the last muster. Every muster shall be carried out under the supervision of one of the vessel's officers and shall be so arranged as to ensure that the crew thoroughly understand and are practised in the duties they have to perform including the fighting of fires, donning of life jackets and handling and operation of life rafts and rescue boats.

A drill should be done on leaving port even if you have only one new crew member on board. The 25% should not be a benchmark figure. In my experience I also found that doing drills on the way to the fishing grounds and

repeating them on the return voyage were the most favourable times to perform the drills as well as most practical as far as timing is concerned.

- (3) When holding musters, the life-saving, fire-fighting and other safety equipment shall be examined to ensure that they are complete and in satisfactory working order.
- (4) A record of each muster shall be made in the official log book and a report of each muster shall be made in the safety officers log book. If no muster is held within the prescribed periods indicated in paragraph 1, a note shall be made in the official log book detailing the reasons for the muster(s) not being held.

101. On Board Training

- (1) The master shall ensure that all members of the crew are well versed and trained in the applicable provisions of the Code of Safe Working Practices for Fishermen and any other Standard Operating Procedures applicable to the vessels safe operation.
- (2) An entry shall be made in the safety officers record book whenever any training is carried out.

102. Short Title and Commencement

These Regulations are called the Draft Merchant Shipping (Construction and Equipment of Fishing Vessels of 24 Metres in Length and Over) Regulations, 2022 and are published for public comments.

ANNEX 1

VESSEL CONSTRUCTION: PLANS AND PARTICULARS

The plans and particulars respecting hull, machinery and equipment to be submitted in accordance with Regulation 1 are as follows:

- (1) Plans:
 - (a) General Arrangement;
 - (b) Lines Plan;
 - (c) Midship section, showing scantlings of shell, decking, bulwarks, frames, floors, stringers and beams;
 - (d) A series of Plan views showing particulars of deck openings, ventilators, air pipes and tanks;
 - (e) Tank Plan and Sounding Tables;
 - (f) An Engine Room Layout Plan;
 - (g) Fuel, Fire, Bilge and Ballast Pumping Arrangement Schematics;
 - (h) Propellor Shaft Arrangement Plan;
 - (i) Rudder and Steering Arrangement Plan;
 - (j) Engine Seating Arrangement;

- (k) Refrigerant system schematics (excluding domestic refrigeration systems);
- (l) Electrical Circuit Diagrams;
- (m) Navigation Light Plan;
- (n) Hydrostatic and Cross Curve Data (Curves or Tables);
- (o) Safety Plan;and
- (p) Watertight Integrity Plan.

(2) Specifications:

- (a) All principal hull members, stating the materials, including keel, stem, stern post, beams, frames, floors, shell and deck and their fastening arrangements;
- (b) Machinery Arrangements, including auxiliary machinery;
- (c) Fuel, Fire, Bilge and Ballast pumping arrangements;
- (d) Fuel pumping arrangements;
- (e) Underwater fittings;
- (f) Bulkheads;
- (g) Hatchways, hatch coamings and covers;
- (h) Deck houses;
- (i) Doors, sills, side scuttles and escape hatches;
- (j) Bulwarks;
- (k) Ventilation;
- (l) Tanks;
- (m) Anchors, cables and windlass;

- (n) Winches, masts and derricks;
- (o) Steering Gear;
- (p) Crew Accommodation;
- (q) Lifeboat / Rescue Boat and Life Raft stowage and launching arrangements;
- (r) Other Life Saving and Fire Fighting Equipment which is integral with the vessels structure;
- (s) Navigation Lights and Sound Signals; and

- (t) Electrical Arrangements.

ANNEX 2

ANCHORING, MOORING AND TOWING EQUIPMENT

| Equipment Number | Stockles s Bow Anchors Mass per Anchor [kg] | Chain Cable | | Towline (Steel or Fibre ropes) | | Mooring Lines (Steel or fibre ropes) | | |
|------------------|--|------------------------|---|-----------------------------------|---|---|-------------------------|---|
| | | Total Length [m] | Minimum Breaking Strength [kN] | Minimum Length [m] | Minimum Breaking Strength [kN] | No | Length (each) [m] | Minimum Breaking Strength [kN] |
| 50-60 | 120 | 192.5 | 72 | 180 | 98 | 3 | 80 | 34 |
| 60-70 | 140 | 192.5 | 72 | 180 | 98 | 3 | 80 | 34 |
| 70-80 | 160 | 220 | 92 | 180 | 98 | 3 | 100 | 37 |
| 80-90 | 180 | 220 | 92 | 180 | 98 | 3 | 100 | 37 |
| 90-100 | 210 | 220 | 116 | 180 | 98 | 3 | 110 | 39 |
| 100-110 | 240 | 220 | 116 | 180 | 98 | 3 | 110 | 39 |
| 110-120 | 270 | 247.5 | 150 | 180 | 98 | 3 | 110 | 44 |
| 120-130 | 300 | 247.5 | 150 | 180 | 98 | 3 | 110 | 44 |
| 130-140 | 340 | 275 | 179 | 180 | 98 | 3 | 120 | 49 |
| 140-150 | 390 | 275 | 179 | 180 | 98 | 3 | 120 | 49 |
| 150-175 | 480 | 275 | 211 | 180 | 98 | 3 | 120 | 54 |
| 175-205 | 570 | 302.5 | 244 | 180 | 112 | 3 | 120 | 59 |
| 205-240 | 660 | 302.5 | 280 | 180 | 129 | 4 | 120 | 64 |
| 240-280 | 780 | 330 | 332 | 180 | 150 | 4 | 120 | 69 |
| 280-320 | 900 | 357.5 | 389 | 180 | 174 | 4 | 140 | 74 |
| 320-360 | 1020 | 357.5 | 449 | 180 | 207 | 4 | 140 | 78 |
| 360-400 | 1140 | 385 | 514 | 180 | 224 | 4 | 140 | 88 |

| | | | | | | | | |
|---------|------|-------|-----|-----|-----|---|-----|-----|
| 400-450 | 1290 | 385 | 583 | 180 | 250 | 4 | 140 | 98 |
| 450-500 | 1440 | 412.5 | 655 | 180 | 277 | 4 | 140 | 108 |
| 500-550 | 1590 | 412.5 | 732 | 190 | 306 | 4 | 160 | 123 |
| 550-600 | 1740 | 440 | 812 | 190 | 338 | 4 | 160 | 132 |
| 600-660 | 1920 | 440 | 896 | 190 | 371 | 4 | 160 | 147 |
| 660-720 | 2100 | 440 | 981 | 190 | 406 | 4 | 160 | 157 |

ANNEX 3

INFORMATION TO BE PROVIDED IN STABILITY BOOKS

- (1) The information shall be in the form of plans, statements, tables and diagrams drawn up separately or appropriately grouped. The information provided shall be in English and shall include:
- (a) The name of the company and person who has prepared the stability information;
 - (b) The vessels principal dimensions;
 - (c) A general description of the ship including its history, mode of operation and voyage profile;
 - (d) A list of applicable documentation and drawings used for the compilation of the stability book;
 - (e) A summary of the stability criteria applicable to the vessel;
 - (f) If any special procedure is required to ensure adequate stability throughout a voyage, while alongside or during dry-docking, instructions for the attention of the master and chief engineer shall be provided;
 - (g) A statement defining the lightship condition of the ship as determined by an inclining experiment;
 - (h) Instructions on the use of the stability book highlighting any assumptions made for the information presented and including an example calculation, for the reference of the master and chief engineer, showing how the vessel stability can be checked using maximum VCG curves;
 - (i) A general notice on precautions against capsizing using the applicable paragraphs of Annex 2 of this Chapter plus any other necessary

- precautions which may be identified;
- (j) The vessel downflooding points shall be identified and curves drawn depicting the angle of down flooding versus expected operational draught for the first point of down flooding for each hydrostatic trim provided;
 - (k) Maximum VCG curves, which ensure vessel compliance with applicable stability criteria, for the range of expected vessel displacements and trims. Trims should be linked to the position of the vessel's LCG;
 - (l) A profile and plan view of the ship drawn to a suitable scale showing thereon or in associated tables:
 - (i) the position of the fore and aft perpendiculars as well as the vessels baseline. The vessel's baseline should preferably be the moulded baseline;
 - (ii) The position of spaces available for the carriage of cargo, fuel, stores, feed water, domestic water and ballast water;
 - (iii) The weight and position of any installed fixed ballast; and
 - (iv) The enclosed volume assumed for the compilation of cross curve (KN) data;
 - (m) For each load condition which the vessel is required to be evaluated, the following information shall be provided:
 - (i) Diagrams (profile and plan views, as required) drawn to a suitable scale and statements showing the lightship weight, the position of permanent ballast, if any, and total weights of all components of the weight shall be provided, for each load condition evaluated;
 - (ii) The vessel's displacement, vertical centre of gravity and longitudinal centre of gravity, free surface correction, KM and GM_0 .

- (iii) Vessel trim information, clearly indicating whether the reference point is the baseline, underside of keel or other;
 - (iv) Draught at forward perpendicular, amidships and aft perpendicular. Draughts at the vessel's draught marks may also be required;
 - (v) Tabulated values of KN for the range of stability being evaluated.
 - (vi) A curve of statical stability (righting lever curve), corrected for free surface, with the angle of downflooding clearly indicated thereon;
 - (vii) The vessels freeboard;and
 - (viii) A summary of results indicating compliance or non-compliance of the vessel with the applicable stability criteria. The criteria of Regulations 3 and 5 shall apply to all vessels. The criteria of Regulations 6, 8, 9,10, 13 and 14 shall only be applicable in respect of certain vessel types and areas of operation.
- (n) An inclining experiment report detailing the inclining experiment procedure and results obtained. Inclining experiments shall be conducted in accordance with guidance laid down by the Authority;
- (o) Hydrostatic and cross curves of stability data (calculated on a free trimming basis), in tabular format, for the range of displacements and trims to be expected in normal operating conditions. The range of trims provided shall be such that the trim steps provided are not more than 2% of LBP and that any extrapolation required is within 1% of LBP. The enclosed volumes used for the calculation of the vessel's cross curves shall be identified;
- (p) Tank sounding tables providing tank sounding, volume, weight, VCG, LCG, TCG (if necessary) and free surface information;

ANNEX 4

GENERAL PRECAUTIONS AGAINST CAPSIZING AND FLOODING FOR SHIPS

- (1) Compliance with the stability criteria does not ensure immunity against capsizing, regardless of the circumstances, or absolve the master from his responsibilities. Masters should therefore exercise prudence and good seamanship, having regard to the season of the year, weather forecasts and the navigational zone, and should take the appropriate action as to speed and course warranted by the prevailing circumstances.
- (2) Before a voyage commences, care should be taken to ensure that sizeable pieces of equipment and stores have been properly stowed or lashed so as to minimize the possibility of both longitudinal and lateral shifting, while at sea, under the effect of acceleration caused by rolling and pitching.
- (3) A ship, when engaged in towing operations, should not carry deck cargo, except that a limited amount, properly secured, which would neither endanger the safe working of the crew on deck nor impede the proper functioning of the towing equipment, may be accepted.
- (4) The number of partially filled or slack tanks should be kept to a minimum because of their adverse effect on stability.
- (5) The stability criteria contained in these regulations set minimum values, but no maximum values are recommended. It is advisable to avoid excessive values of metacentric height, since these might lead to acceleration forces which would be prejudicial to the ship, its complement, its equipment and to safe carriage of cargo.
- (6) All doorways and other openings through which water can enter into the hull, deck-houses, forecastle, etc., should be suitably closed in adverse weather conditions and accordingly all appliances for this purpose should be maintained on board and in good condition.

- (7) Weathertight and watertight hatches, doors, etc., should be kept closed during navigation, except when necessarily opened for the working of the ship, and should always be ready for immediately closure and be clearly marked to indicate that these fittings are to be kept closed except for access. Hatch covers and flush deck scuttles in fishing vessels should be kept properly secured when not in use during fishing operations. All portable deadlights should be maintained in good condition and securely closed in bad weather.
- (8) Any closing devices provided for vent pipes to fuel tanks should be secured in bad weather.
- (9) Reliance on automatic steering may be dangerous as this prevents ready changes to course which may be needed in bad weather.
- (10) In all conditions of loading, care should be taken to maintain a seaworthy freeboard.
- (11) In severe weather, the speed of the ship should be reduced if excessive rolling, propeller emergence, shipping of water on deck or heavy slamming occurs. Six heavy slammings or 25 propeller emergencies during 100 pitching motions should be considered dangerous.
- (12) Special attention should be paid when a ship is sailing in following or quartering seas because dangerous phenomena such as parametric resonance, broaching to, reduction of stability on the wave crest, and excessive rolling may occur singularly, in sequence or simultaneously in a multiple combination, creating a threat of capsizing. Particularly dangerous is the situation when the wave length is of the order of 1.0 to 1.5 ship's length. A ship's speed and / or course should be altered appropriately to avoid the above-mentioned phenomena.
- (13) Water trapping in deck wells should be avoided. If freeing ports are not sufficient for the drainage of the well, the speed of the ship should be reduced or the course changed, or both. Freeing ports provided with closing appliances should always be capable of functioning and are not to be locked.

- (14) Masters should be aware that steep or breaking waves may occur in certain areas, or in certain wind and current combinations (river estuaries, shallow water areas, funnel-shaped bays, etc.) These waves are particularly dangerous, especially for small ships.
- (15) The use of operational guidelines for avoiding dangerous situations in severe weather conditions or an on-board computer-based system is recommended. The method should be simple to use.
- (16) Additional fishing operation specific precautions
- (a) All fishing gear and other large weights should be properly stowed and placed as low as possible.
 - (b) Particular care should be taken when the pull from fishing gear might have a bad effect on stability e.g., when nets are hauled by power-block or the trawl catches obstructions on the sea-bed.
 - (c) Gear for releasing deck load in fishing vessels carrying catch on deck, e.g., herring, should be kept in good working condition for use if necessary.
 - (d) When the main deck is prepared for the carriage of deck load by division with pound boards, there should be slots between them of suitable size to allow easy flow of water to freeing ports to prevent trapping of water.
 - (e) Fish should never be carried in bulk without first being sure that the portable divisions in the holds are properly installed.
 - (f) Particular care should be taken when the pull from fishing gear results in dangerous heel angles. This may occur when fishing gear fastens onto an underwater obstacle or when handling fishing gear, particularly on purse seiners, or when one of the trawl wires tears off. The heel angles caused by the fishing gear in these situations may be eliminated by employing devices which can relieve or remove excessive forces applied through the fishing gear. Such devices should

not impose a danger to the vessel through operating in circumstances other than those for which they were intended.

(17) Additional bilge/ejector operation specific precautions:

- (a) keep the bilge pump, bilge ejectors and bilge system in a well maintained condition;
- (b) regularly check spaces not fitted with a high level alarm for water ingress;
- (c) regularly check high level alarms;
- (d) weekly checks of bilge strainers and mud boxes and clean if required;
- (e) clean grids for fish hold suctions whenever possible and always prior to loading of the catch;
- (f) check that all valves within the bilges/ejector system are checked at monthly intervals locally, and in the case where fitted, remotely;
- (g) check and test bilge and other pumps not in regular use on a monthly basis;
- (h) keep areas where suctions are located free of rubbish and debris;
- (i) any modifications to the bilge/ejector system and factory deck anti-flooding systems are to be advised to the Authority for approval;

ANNEX 5

SEVERE WIND AND ROLLING CRITERION (WEATHER CRITERION)

- (1) The ability of a ship to withstand the combined effects of beam wind and rolling should be demonstrated with reference to figure 1 as follows:
 - (a) The ship is subjected to a steady wind pressure acting perpendicular to the ship's centreline which results in a steady wind heeling lever (l_{w1});
 - (b) from the resultant angle of equilibrium (ϕ_0), the ship is assumed to roll owing to wave action to an angle of roll (ϕ_1), to windward. Attention should be paid to the effect of steady wind so that excessive resultant angles of heel are avoided. The angle of heel due to steady wind (ϕ_0), should not exceed 16° or 80% of the angle of deck edge immersion, whichever is less;
 - (c) the ship is then subjected to a gust wind pressure which results in a gust wind heeling lever (l_{w2});
 - (d) under these circumstances, area b should be equal to or greater than area a; and

- (e) free surface effects should be accounted for in the standard conditions of loading

Figure 1 – Severe wind and rolling

- (2) The wind heeling levers and referred to in paragraphs (1)(a) and (1)(c) are constant values at all angles of inclination and should be calculated as follows:

$$l_{W1} = \frac{PAZ}{1000 g} \text{ [m]} \text{ and } l_{W2} = 1.5 l_{W1} \text{ [m]}$$

where:

P = as calculated in accordance with the table below. The value of P used for ships in restricted service may be reduced, subject to the approval of the Authority;

| | | | | | | |
|-----------------------|-----|-----|-----|-----|-----|------------|
| h [m] | 1 | 2 | 3 | 4 | 5 | 6 and over |
| P [N/m ²] | 316 | 386 | 429 | 460 | 485 | 504 |

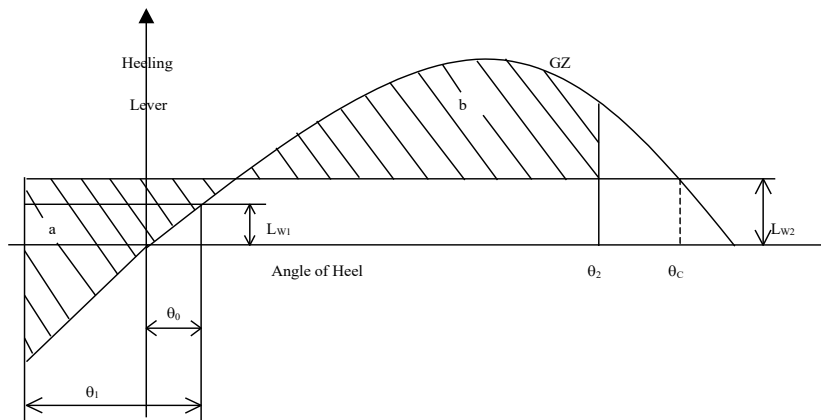

- θ_o = angle of heel under action of steady wind.
- θ_1 = Angle of roll to windward due to wave action
- θ_2 = Angle of downflooding or 50° or θ_c whichever is less
- θ_c = Angle of 2nd intercept between wind heeling lever (l_{W2}) and GZ curve.

where h is the vertical distance from the centre of the projected vertical area of the ship above the waterline to the waterline.

A = projected lateral area of the portion of the ship and deck cargo above the waterline [m²];

Z = vertical distance from the centre of A to the centre of the underwater lateral area or approximately to a point at one half the draught [m];

Δ = displacement [t] and;

g = 9.81 [m/s²]

(3) The angle of roll (ϕ_1) referred to in paragraph (1)(b) should be calculated as follows:

$$\phi_1 = 109 k X_1 X_2 \Delta^{0.75} \text{ [degrees]}$$

where

X1 = factor as shown in table 2

X2 = factor as shown in table 3

k = factor as follows:

k = 1.0 for a round-bilged ship having no bilge or bar keels

k = 0.7 for a ship having sharp bilges

k = as shown in table 4 for a ship having bilge keels, a bar keel or both.

$$r = 0.73 \Delta^{0.6} \text{ OG/d}$$

with: OG = distance between the centre of gravity and the waterline, [m]

(+ if the centre of gravity is above the waterline, - if it is below)

d = mean moulded draught of the ship [m].

s = factor as shown in table 5

| | |
|-----|----------------|
| B/d | X ₁ |
|-----|----------------|

| | |
|----------------|----------------|
| C _B | X ₂ |
|----------------|----------------|

| | |
|-------|------|
| □ 2.4 | 1.0 |
| 2.5 | 0.98 |
| 2.6 | 0.96 |
| 2.7 | 0.95 |
| 2.8 | 0.93 |
| 2.9 | 0.91 |
| 3.0 | 0.90 |
| 3.1 | 0.88 |
| 3.2 | 0.86 |
| 3.4 | 0.82 |
| □ 3.5 | 0.80 |

Table 2 – Values of factor X_1

| | |
|--------|------|
| □ 0.45 | 0.75 |
| 0.50 | 0.82 |
| 0.55 | 0.89 |
| 0.60 | 0.95 |
| 0.65 | 0.97 |
| □ 0.70 | 1.00 |

Table 3 – Values of factor X_2

| <u>Ak x 100</u> | |
|-----------------|------|
| L x B | K |
| 0 | 1.0 |
| 1.0 | 0.98 |
| 1.5 | 0.95 |
| 2.0 | 0.88 |
| 2.5 | 0.79 |
| 3.0 | 0.74 |

| T | S |
|-----|-------|
| □ 6 | 0.100 |
| 7 | 0.098 |
| 8 | 0.093 |
| 12 | 0.065 |
| 14 | 0.053 |
| 16 | 0.044 |

| | |
|-------|------|
| 3.5 | 0.72 |
| □ 4.0 | 0.70 |

Table 4 – Values of factor k
factor s

| | |
|------|-------|
| 18 | 0.038 |
| □ 20 | 0.035 |

Table 5 – Values of

(Intermediate values in these tables should be obtained by linear interpolation)

Rolling period $T = \frac{2 C B}{GM}$ [s]

□ GM

where: $C = 0.373 + 0.023 (B/d) - 0.043 (L/100)$

The symbols in the above tables and formula for the rolling period are defined as follows:

- L = waterline length of the ship [m]
- B = moulded breadth of the ship [m]
- d = mean moulded draught of the ship (m)
- C_B = block coefficient
- A_k = total overall area of bilge keels, or area of the lateral projection on the bar keel, or sum of these areas [m²].
- GM = metacentric height corrected for free surface effect [m].

ANNEX 6

ICING CONSIDERATIONS

- (1) For vessels operating in areas where ice accretion is likely to occur, the following icing allowance should be made in the stability calculations:
 - (a) 30 kg per square metre on exposed weather decks and gangways;
 - (b) 7.5 kg per square metre for projected lateral area of each side of the

vessel above the water plane;and

- (c) The projected lateral area of discontinuous surfaces of rail, sundry booms, spars (except masts) and rigging of vessels having no sails and the projected area of other small objects shall be computed by increasing the total projected area of continuous surfaces by 5% and the static moments of this area by 10%.
- (2) In the application of the above standards, the following ice areas shall apply:
- (a) the area north of of Latitude 65°30'N, between Longitude 28°W and the west coast of Iceland; north of the north coast of Iceland; north of the rhumb line running from Latitude 66°N, Longitude 15°W to Latitude 73°30'N, Longitude 15°E, north of Latitude 73°30'N between Longitude 15°E and 35°E, and east of Longitude 35°E, as well as north of Latitude 56°N in the Baltic sea;
 - (b) the area north of Latitude 43°N bounded in the west by the North American coast and in the east by the rhumb running from Latitude 43°N, Longitude 48°W to Latitude 63°N, Longitude 28°W and thence along Longitude 28°W;
 - (c) all seas north of the North American Continent, west of the areas defined in (a) and (b);
 - (d) the Bering and Okhotsk Seas and the Tartary Strait during the ice season; and
 - (e) South of Latitude 60°S.
- (3) For vessels operating within the areas defined above:
- (a) For vessels operating in the areas defined in (a), (c), (d) and (e) known to have ice conditions significantly different from those described in paragraph (1), ice accretion requirements of one half to twice the required allowance may be applied at the discretion of the Authority;

and

- (b) For vessels operating within the area defined in (b), where ice accretion in excess of twice the allowance required by paragraph (1) may be expected, more severe allowances may be applied at the discretion of the authority.

ANNEX 7

Regulation 10

LIFTING OF HEAVY WEIGHTS OVER THE SIDE

- (1) The ability of a ship to withstand the effects of lifting heavy weights over the side should be demonstrated as follows:

- (a) The weight is initially assumed to be on the upper deck on the centreline of the vessel;

- (b) With reference to the figure below, the heeling arm curve is calculated as follows:

Heeling arm = $\frac{w a \cos \theta}{W}$ with w = weight, [tonnes]
 a = eccentricity of max point of extension from ships centreline, [m]
 W = Ships displacement, [tonnes]
 θ = Angle of inclination, [deg]

- (c) Criteria with reference to figure 1 below, stability is considered satisfactory if:

- (i) The angle of heel (at point C) is less than 15 degrees (subject to crane operating restrictions);

- (ii) The heeling arm (GZ) at the intersection of the righting arm and heeling arm curves (point C) is less than six tenths of the maximum righting arm value;
- (iii) The reserve of dynamic stability (shaded area) is greater than four tenths of the total area under the righting arm (GZ) curve;

Figure 1 - Lifting of Heavy weights over the side

ANNEX 8

MINIMUM FREEBOARD AND BOW HEIGHT

General requirements:

- (1) The structure of the vessel must be appropriate to the loading of the vessel. This means that where a scantling draft has been set by a classification society, this should not be exceeded . Where no such draft has been set the owner shall satisfy the Authority that the structure of the vessel is capable of

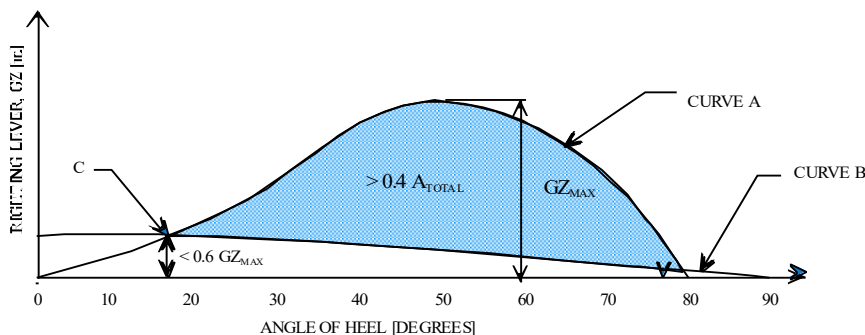

withstanding the proposed loading of the vessel by submitting information (including calculations where performed) demonstrating compliance with a

recognised structural standard.

- (2) The waterline should not pass above the main deck level at any point in way of exposed main decks or non-weathertight shelters. However, the arrangement of any given vessel may be such that due to a combination of trim and sheer, and provided all other requirements for freeboard and structure are met, the waterline may pass above the main deck in way of a weathertight shelter.

Bow height (H_B)

- (3) Flush decked vessels

- (a) The value of the bow height, H_B , in metres, shall be given by:

$$H_B = 0.117 L \times (1 - L/220) \text{ metres}$$

or, for existing vessels;

$$H_B = 1 + (L/16) \text{ metres, if less.}$$

- (b) Where the bow height is obtained by sheer, this should extend from the stem to at least $0.15L$ aft of the Forward Perpendicular (see Figure 1b).
- (c) Where a bulwark is fitted, this may be taken into account for a height of up to one metre provided that the bulwark extends from the stem to

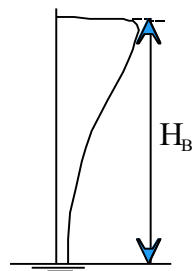

Figure 1a

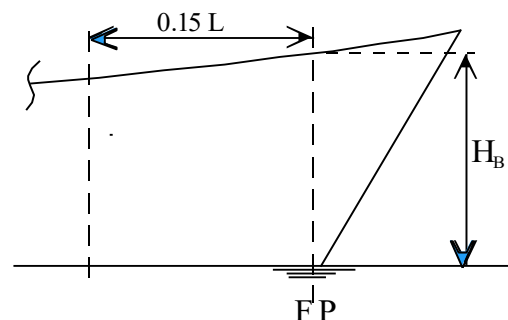

Figure 1b

a point $0.15L$ aft of the Forward Perpendicular (see Figure 2a).

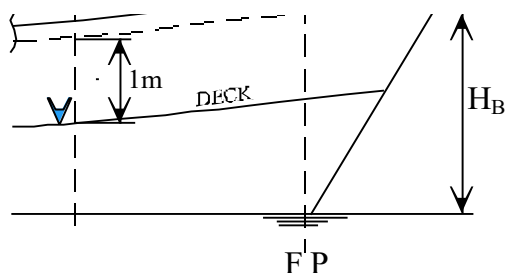

Figure 2a

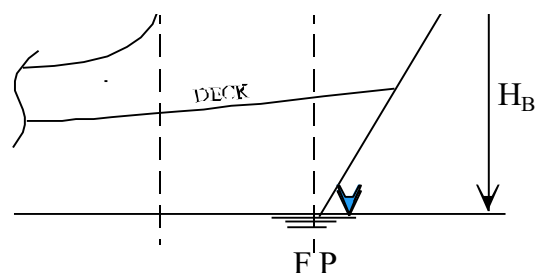

Figure 2b

(4) Vessels with a forecastle

- (a) The bow height of vessels with a weathertight or non-weathertight forecastle may be measured from the forecastle deck, provided the forecastle extends from the stem to at least $0.07 L$ aft of the Forward Perpendicular (see Figure 2b). A non-weathertight forecastle extending more than $0.15L$ should be fitted with means of draining water from the shelter.
- (a) Where a bulwark is fitted, this may be taken into account for a height of up to one metre provided that the bulwark extends from the stem to a point $0.15L$ aft of the Forward Perpendicular.

Aft freeboard (H_{DA})

(5) General principals

- (a) The general aim to provide adequate protection against the vessel being pooped and to ensure that adequate aft freeboard is maintained to reduce, as far as possible:
- (i) danger to crew working on deck from green seas shipped over the stern,
 - (ii) downflooding through doors hatches vent or pipes, and
 - (iii) loss of stability due to water trapped on deck.
- (b) In flush decked vessels, H_{DA} , should be regarded as adequate to fulfil

the above requirements. Reduced freeboards may be considered for vessels where the arrangement of superstructures provides greater protection in **all** the above categories. As vessels vary considerably in design, all relevant aspects of the arrangement and operation of the vessel should be taken into account, for example sub-paragraph

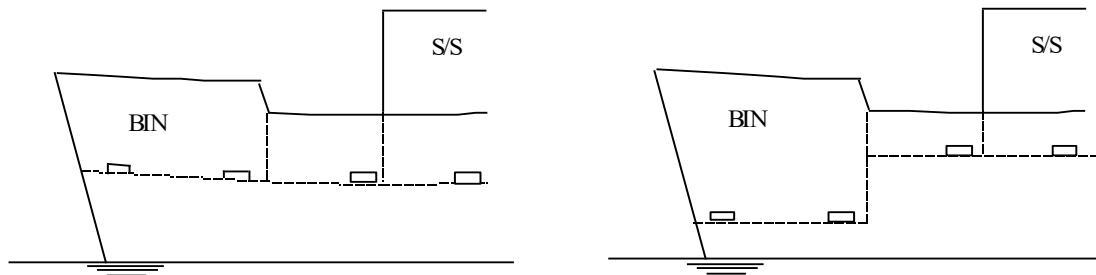

(5)(a)(i) would not be as important for a vessel where crew do not work on the after deck at sea.

- (c) The following paragraphs set out the requirements for aft freeboard given various arrangements. If the arrangement of a particular vessel does not fit any of the given patterns, then the case should be referred to the Authority.

(6) Flush decked vessels

The value of H_{DA} , in metres, is given by the following formula:

$$H_{DA} = 0.24 + 0.026 L$$

(7) Vessels with exposed stern wells or net bins

- (a) The following conditions should be satisfied for vessels with an exposed after well or a net bin in order to qualify for a reduced after freeboard:
- (i) The well or net bin should not extend further than a line $L/5$ forward of the Aft Perpendicular. Examples of net bin arrangements are shown in Figure 3;
 - (ii) The boundary deck of a well or net bin should be watertight without any

means of access. The only exception, in the case of a well, should be an escape from crew accommodation, where it is not practical to avoid this. The hatch should only be opened in an emergency;

Figure 3a

Figure 3b

Figure 3c

- (iii) The vessel should be watertight up to a height of 600mm above the reference line (see Figure 4) across the full width of the vessel at the forward boundary bulkhead. Where a net bin is positioned on one side, the forward boundary bulkhead should, in conjunction with an adjoining watertight compartment, be watertight up to the same level;

Figure 4

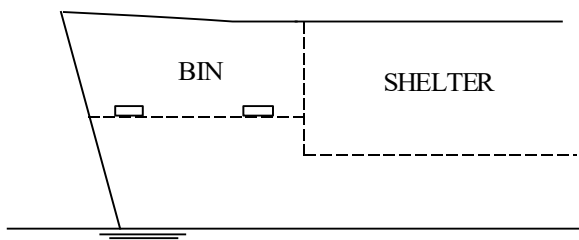

- (iv) There should be no need for frequent operational crew access to the

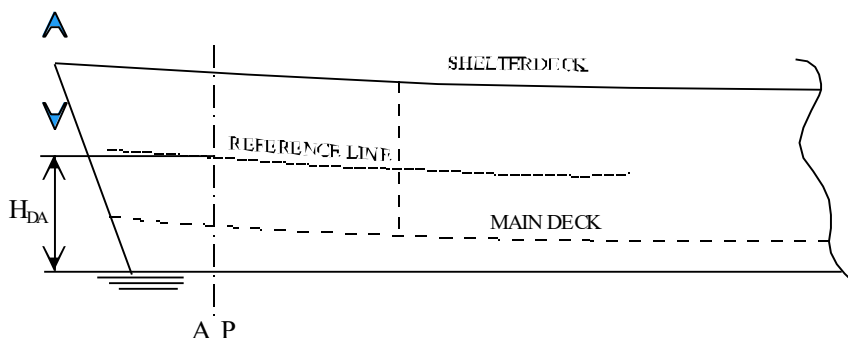

- well or net bin at sea;
- (v) Positioning machinery space ventilator inlets in a well or net bin should be avoided. All ventilator openings should have their lower edge as high and as far inboard as practical and at least 900mm above the reference line;
 - (vi) Air pipes should have the lower edge of their goose neck or bend at least 760mm above the reference line;
 - (vii) If defined, the scantling draft should not be exceeded;
 - (viii) The watertight boundaries of the well or net bin should be of equivalent strength to the main hull. The bulwarks should be of solid construction and extend at least H_{DA} above the deepest waterline;
- (b) The freeboard to the upper deck at the forward bulkhead of the well should not be less than that defined by the reference line;
- (c) Provided all the conditions in sub-paragraph (7)(a)(i) are satisfied and sub-paragraph (7)(d) does not apply, the aft freeboard may be zero to the lower boundary deck of the well or net bin and the minimum freeboard set out in paragraph (14) need not be applied. No operational waterlines should cross the lower boundary deck in way of the well or net bin area in such circumstances the minimum freeboard need to be applied in a way of the well or net bin;
- (d) If the crew are required to access the well or net bin at sea for operational reasons, then the previous sub-paragraph (7)(c) should not be applied. In such cases, the after freeboard should be at least 62.5% of the value of H_{DA} measured from the deepest operational waterline to the lower boundary of the well or net bin at the AP;
- (e) If an access door or hatch (other than an escape hatch) is required in the boundary of the well or net bin, the vessel should meet the full H_{DA} requirement; and

- (f) Where the freeboard to the edge of well deck of less than the minimum freeboard (refer to paragraph 14) at any point in way of the well or net bin, then the freeing port area in way of the well or net bin required by Regulation 19 of Chapter III shall be increased pro rata such that the area is doubled for a zero freeboard.
- (8) Vessels with an enclosed non-weather-tight stern:
- (a) To qualify for a reduced after freeboard, vessels with an enclosed non-weather-tight enclosure aft of a full width superstructure (see Figure 5a), shall satisfy the following conditions:
- (i) The enclosure shall extend from the stern;
 - (ii) The boundary deck of the enclosure shall be weather-tight without any means of access below. The only exception may be an escape hatch from the crew accommodation, should it not be practical to trunk the escape up to an exposed deck. Such a hatch shall only be opened in an emergency;
 - (iii) The forward boundary bulkhead shall be full width and watertight without any openings at least up to a height of 600mm above the reference line;
 - (iv) Machinery space ventilators should not be positioned within the enclosure, unless it is impractical not to do so. Where such ventilator openings are unavoidable, these should be positioned as high and as far inboard as practical and have their lower edge at least 900mm above the reference line;
 - (v) Air pipes within the enclosure should have the lower edge of their goose neck or bend at least 760mm above the reference line;

- (vi) If defined, the scantling draft shall not be exceeded;
- (vii) The boundaries of the enclosure shall be of equivalent strength to the main hull;
- (viii) Freeing ports in accordance with Regulation 19 of Chapter III, or an equivalent passive system capable of removing any water trapped on deck, shall be fitted; and
- (ix) With the enclosure flooded to the height of the bottom of any substantial opening excluding freeing ports, if fitted, the vessel shall still comply with the stability criteria required by this Chapter;

Figure 5a - A: Zero Minimum Freeboard

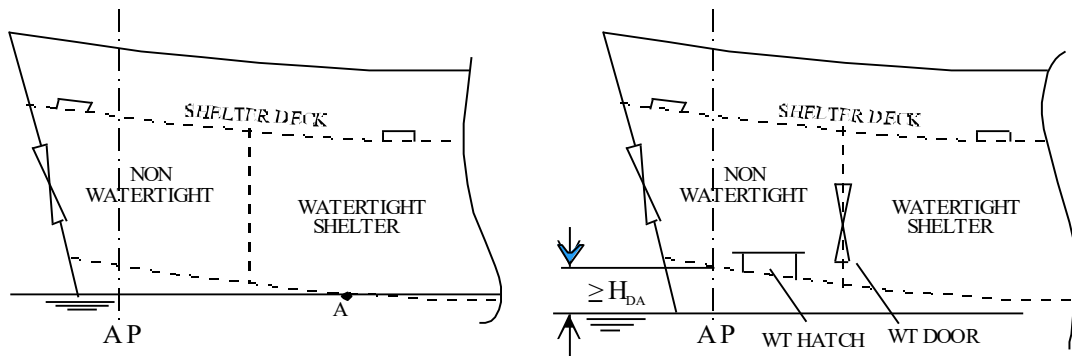
Figure 5b - With Openings
in Well

- (b) Provided all the conditions in sub-paragraph (8)(a) are met, the aft freeboard (H_{DA}) may be zero to the lower boundary deck of the well, provided no operational waterlines cross the lower boundary deck in way of the well area. This effectively limits the operational waterlines to the point A on Figure 5a;
- (c) The reduction in after freeboard shall be restricted to 37.5% of H_{DA} measured from the deepest operational waterline to the lower boundary of the well at the AP if an access hatch or door is required in the boundary of the well (see Figure 5b). Such a hatch or door in the well

should be fully weathertight and be fitted with a 600mm coaming. In all other respects the requirements of sub-paragraph (8)(a) above should be met (the door or hatch should be assumed to be closed for the calculations). Due to the increased risk of flooding, if any further openings are required then no reduction in freeboard shall be granted;

- (d) If the vessel has transom openings which may provide a means of entry for substantial quantities of water in the event of the vessel being pooped, then it should either be demonstrated that the vessel is able to survive rapid flooding of the well up to the level of the openings or the freeing port areas should be increased to enable water to be freed more rapidly; and
 - (e) Where freeboards of less than the minimum freeboard are to be used then the Authority may require that the freeing port area be increased.
- (9) Vessels with an enclosed weathertight stern, poop or raised quarter-deck
- (a) This paragraph applies to vessels with a weathertight poop or full width shelter extending from the stern to a point at least $L/5$ forward of the AP. The shelter should be fully weathertight without any side or weatherdeck openings which are required to be used at sea except weathertight doors and hatches for crew access only. Due to the increased risk of flooding, any weathertight structures with openings for fishing gear may not take advantage of the reduced freeboards in this paragraph unless such openings have a means of closure which enables it to be closed weathertight at any time, including if such an opening is normally open during fishing operations and is of sufficient size to be considered to be a downflooding point. An example would be a small hole in a side opening when monofilament lines are deployed from a long-liner;
 - (b) The principle that should be applied in this circumstance is that the weathertight structure should provide protection against the vessel being pooped. This is achieved by ensuring that hatches, vents and air

pipes are no nearer the deepest operating waterline than would be allowed for a flush decked vessel, thus providing equivalent protection;

- (c) A typical arrangement is given in Figure 6;

Figure 6

- (d) The freeboard may be measured from the poop deck at the AP for compliance with H_{DA} , provided the conditions set out in sub-paragraphs (9)(a) and (9)(b) of are met;
- (e) Where a weathertight poop is fitted but is less than $L/5$ in length but greater than $0.07L$ in length, then the freeboard may continue to be measured from the poop deck level, but the minimum aft freeboard shall be given by the formula:

$$H_{DA} + H_s \times \frac{0.2 - (L_s/L)}{0.13}$$

Where L_s = The length of the poop

H_s = The height of the poop at the AP

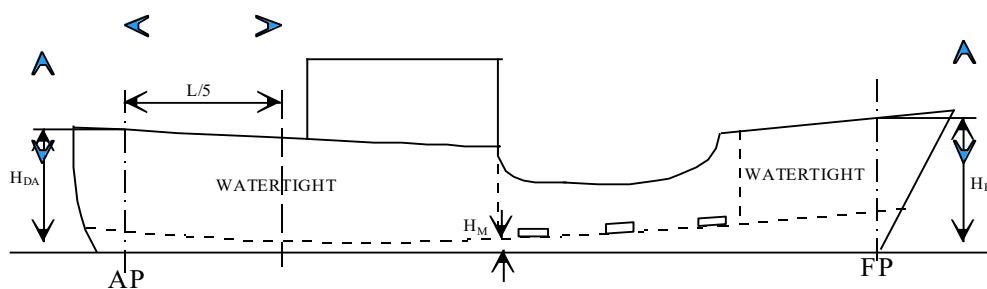

- (g) The minimum freeboard (H_M) set out in paragraph (14) shall be met on all deck areas fitted with freeing ports;
- (h) All exposed access openings in the poop or shelter deck should have coamings as if fitted on the main deck, unless the upper deck is greater than $(H_{DA} + 1.98m)$ above the deepest waterline at the AP, in which case the deck may be treated as a superstructure;

- (i) All ventilators and air pipes shall have coamings and closures as if fitted on an exposed main deck, unless the upper deck is greater than ($H_{DA} + 1.98\text{m}$) above the deepest waterline at the AP, in which case the deck may be treated as a superstructure;
- (10) Vessels with a non-weather-tight enclosed shelter:
- (a) this applies to non-weather-tight enclosed spaces wholly within $L/5$ aft of the FP and $L/5$ fwd of the AP. The area of non-closeable openings shall not exceed (5%) of the deck area of the well (see Figure 7). Balanced freeing ports may be counted as closeable. Figure 8 illustrates the principle that should be used to measure the area of an opening;
 - (b) such spaces may have zero freeboard to the main deck, but no waterlines shall cross the main deck in way of the space and the drainage arrangements shall be able to remove water from the deck rapidly and effectively. If the area of any opening which may be opened at sea is greater than (5% of the area of the shelter), then the shelter should be treated as open or exposed;
 - (c) the lowest edge of any side opening in the shelter shall be above the bulwark height specified by Regulation 3 of Chapter VII unless it is required to be otherwise for operational reasons. In such circumstances the Authority shall be satisfied that adequate provision is made for the safety of the crew whilst the side opening is in use;

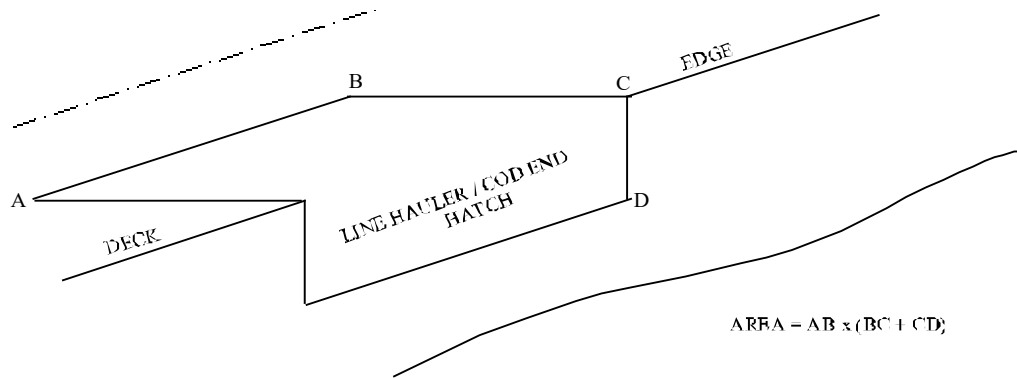
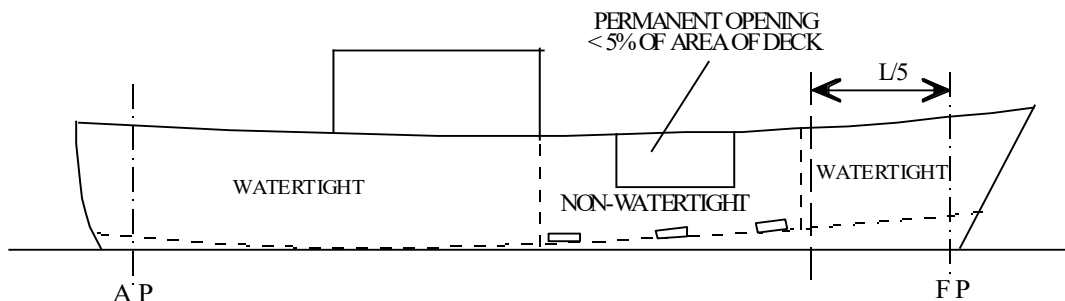

Figure 7 - Enclosed centre well

Figure 8 - Calculation of Hatch Area

(11) Calculations of aft freeboard:

- (a) The preceding paragraphs have set out the requirements for determining the aft freeboard given various vessel arrangements. Reference should be made to the appropriate paragraph in order to determine the critical requirement in relation to the actual arrangement of the vessel, taking account of the positions of air pipes, ventilators openings; and



- (b) When presenting aft freeboard values in each condition for stability submissions, the critical point should be defined and freeboards given from this point to each operational waterline;

Minimum freeboard (H_M)

- (12) A minimum freeboard is required in order to ensure that water can be freed from an exposed deck rapidly and effectively through freeing ports, thus providing a safe working platform for crew working on the deck and avoiding any build up of water which may result in reductions in stability or downflooding.
- (13) The minimum freeboard should be applied to all deck areas where freeing ports or decks lined with rails are fitted with the exception of net bins at any point along the length of the vessel., except in way of net bins or wells as defined in paragraph 3.
- (14) The minimum freeboard, in metres, should be derived from the following formula:

$$H_M = \frac{kL}{B} \quad \text{where } k = 0.117 - 0.0015L$$

The minimum freeboard need not be applied in way of enclosed shelters where freeing ports are not fitted, but this does not remove the need for the provision of efficient drainage.

ANNEX 9

FLOW CHART FOR THE RELIABILITY

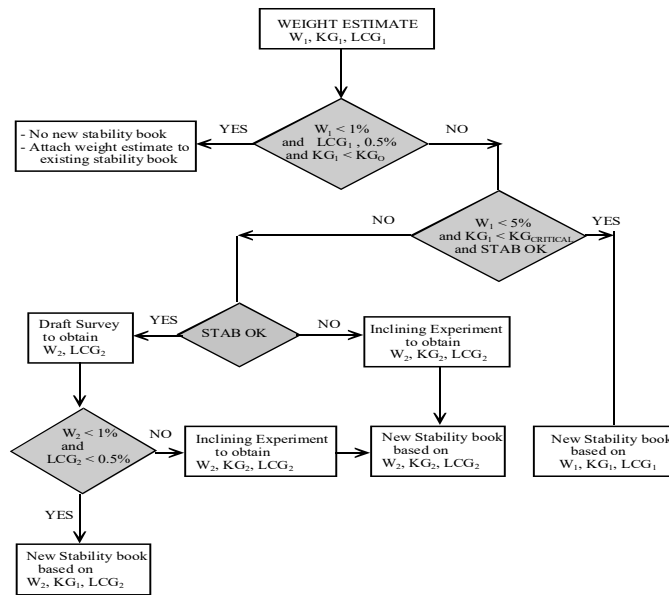

OF STABILITY INFORMATION

When a ship is converted or modified so that the lightship changes, the following process is to be followed:

NOTE

4. W_0, KG_0, LCG_0 = Original lightship ship particulars (obtained from inclining experiment).
- W_1, KG_1, LCG_1 = Estimated new lightship particulars.
- W_2, KG_2, LCG_2 = Lightship particulars (obtained from a draft survey / inclining experiment).

$$2. \quad \square W_{\square 1} = \frac{\square W_{\square 1} - W_{\square 0}}{W_{\square 0}} ; \quad \square W_{\square 2} = \frac{\square W_{\square 2} - W_{\square 0}}{W_{\square 0}}$$

$$\square LCG_1 = \frac{\square LCG_1 - LCG_0}{LCG_0} ; \quad \square LCG_2 = \frac{\square LCG_2 - LCG_0}{LCG_0}$$

$$KG_{\text{CRITICAL}} = KG_0 + 0.1 \text{ m}$$

3. STAB OK means that in all statutory load conditions, the GM_0 is greater than 0.5 m and the GZ value reaches 0.5 m at an angle greater than or equal to 30°.

ANNEX 10 - MAXIMUM RECOMMENDED NOISE LEVELS

1. The following table illustrates the acceptable maximum daily noise doses for unprotected ears, based on dB(A) sound energy received;

| Sound Energy Received; dB(A) | Recommended Maximum Duration for Unprotected Ears |
|------------------------------|---|
| <i>Less than 80</i> | no limit (24 hours) |
| 82 | 16 hours |
| 85 | 8 hours |
| 90 | 2 hours |
| 95 | 50 minutes |
| 100 | 15 minutes |
| 105 | 5 minutes |
| 110 | 1 minute |

2. Examples of noise levels in different locations to allow personnel to gauge the existence of conditions giving potentially harmful noise exposure;
- 120 dB(A) Between two running 1800 rpm diesel generators
- 110 dB(A) In a small ship engine room with 900 rpm diesel main engines and 1550 rpm generator
- 105 dB(A) 1 metre from the engine tops of a slow speed (120 rpm) diesel main engine

| | |
|-----------|---|
| 100 dB(A) | between two running 600 rpm diesel generators |
| 95 dB(A) | in a slow speed (120 rpm) diesel main engine room at the aft end of the floor plate level |
| 90 dB(A) | machine shop or quieter parts of a ship's engine room |
| 80 dB(A) | 15 metres from a pneumatic drill |
| 70 dB(A) | vacuum cleaner at 3 metres |
| 60 dB(A) | inside a supermarket |
| 50 dB(A) | inside a house in a suburban area during daytime |
| 1000000dB | in a toilet after eating a vindaloo |

Note: The levels provided are typical values - engine noise varies considerably with type of installation.

ANNEX 11

TRUNKED MECHANICAL VENTILATION SYSTEMS

- (1) Trunked mechanical ventilation systems shall be capable of the standards of performance tabled below.
- (2) If any store room is served by a fan which provides warmed air for any other space, the store room shall be provided with ventilation trunking separate from that serving such other space.
- (3) The clear area of the exhaust openings provided in conjunction with the system shall be sufficient to ensure that the velocity of air at each opening does not exceed 5 metres per second when the system is in operation.
- (4) The system shall be quiet in operation
- (5) All trunking forming part of the system shall be provided with non-return flaps where such flaps are necessary for the exclusion of effluvia and the

preservation of health of the crew.

- (6) If the system is designed to circulate heated air as the sole means of heating the crew accommodation, the system shall be sub-divided into sections which can be separately controlled to the extent necessary to enable comfortable temperature to be maintained in all parts of the crew accommodation.

| Category | Description of Space | Fresh air changes per hour | Volume of fresh air, in m³/min, for each person likely to use the room at any one time |
|-----------------|---|-----------------------------------|--|
| A | Rooms (other than rooms in category C) in deck houses above the upper or shelter deck: | | |
| | (1) Outside rooms (Not adjoining machinery casing). | 10 | 1.4 |
| | (2) Inside rooms and rooms adjoining machinery casing. | 15 | 1.4 |
| B | Rooms (other than rooms in category C) in side to side superstructures above the upper or shelter deck: | | |
| | (1) Outside rooms (Not adjoining machinery casing). | 12 | 1.4 |
| | (2) Inside rooms and rooms adjoining machinery casing. | 15 | 1.4 |
| C | Mess rooms, smoking rooms and recreation rooms (above the upper or shelter deck) | | |
| | (1) Not adjoining machinery casing. | 15 | 0.7 (a) |
| | (2) Adjoining the machinery casing. | 18 | 0.7 (a) |
| D | Passageways adjoining machinery casings | 4 | - |
| E | Rooms in tween decks | | |
| | (1) Not adjoining machinery casing. | 12 | 1.4 |
| | (2) Abreast but not adjoining the machinery casing. | 12 | 1.4 |
| | (3) Adjoining machinery casings (other than mess rooms, smoking rooms and recreation rooms). | 15 | 1.7 |
| | (4) Mess rooms, smoking rooms and recreation rooms (Adjoining machinery rooms) | 18 | 0.7 |
| Category | Description of Space | Fresh Air Changes per hour | |

| | | Supply | Exhaust |
|---|---|-----------------------|---------|
| F | Galleys | 20 (c) (d) | 40 (d) |
| G | Sanitary accommodation, drying rooms and pantries | 10 | - |
| H | Dry Provision store rooms | > 10 (e), but < 20 | |

- (a) Whatever the number of persons likely to use the room at any one time, the total volume of fresh air per minute shall not be required to be such as would result in more than 20 fresh air changes per hour;
- (b) Whatever the number of persons likely to use the room at any one time, the total volume of fresh air per minute shall not be required to be such as would result in more than 25 fresh air changes per hour;
- (c) 15, if at least two sides of the galley are exposed to the weather;
- (d) The Authority may exempt any vessel from these requirements if satisfied that compliance is unnecessary by reason of the insulation of the equipment in the galley, or by reason of the size of the galley; and
- (e) Subject to Regulation: