

**DEPARTMENT OF TRADE AND INDUSTRY  
DEPARTEMENT VAN HANDEL EN NYWERHEID**

No. R. 273

28 February 2003

**STANDARDS ACT, 1993**

**PROPOSED AMENDMENT OF THE COMPULSORY SPECIFICATION FOR  
MOTOR VEHICLES OF CATEGORY O<sub>3</sub> AND O<sub>4</sub>**

It is hereby made known under section 22 (3) of the Standards Act, 1993 (Act No. 29 of 1993), that the Minister of Trade and Industry intends to amend the compulsory specification for motor vehicles of category O<sub>3</sub> and O<sub>4</sub> published by Government Gazette No. R536 of 14 May 1999 as set out in the Schedule.

Any person who wishes to object to the intention of the Minister to thus amend the compulsory specification concerned, shall lodge their objection in writing with the President, South African Bureau of Standards, Private Bag X191, Pretoria, 0001, on or before the date two (2) months after publication of this notice.



**A Erwin  
Minister of Trade and Industry**

## SCHEDULE

### COMPULSORY SPECIFICATION FOR CATEGORY O<sub>3</sub> AND O<sub>4</sub> VEHICLES (TRAILERS)

#### 1 Scope

**1.1** This specification covers the requirements for vehicles of category O<sub>3</sub> and O<sub>4</sub> designed or adapted for the conveyance of goods and for operation on a public road, including any category O<sub>3</sub> and O<sub>4</sub> vehicle not previously registered in South Africa.

NOTE New vehicles of category O<sub>3</sub> and O<sub>4</sub> designed and constructed for the purpose of the carriage of passengers, as in a semi-trailer bus, are also subject to the relevant requirements for category M<sub>2</sub> and M<sub>3</sub> motor vehicles (buses).

**1.2** The requirements of the specification shall, in so far as the parts already incorporated are concerned, apply in respect of an incomplete vehicle supplied for further manufacture by one manufacturer to another, and the entire specification shall apply to the vehicle after completion thereof by the last-mentioned manufacturer.

**1.3** The specification does not apply to experimental or to prototype trailers constructed or imported by the original manufacturer or by importers for the purpose of testing, assessment or development, or to those military trailers that embody ordnance or missile systems, or to agricultural trailers.

**1.4** The relevant requirements of this specification that take effect on any specified date, shall not apply to vehicles manufactured or imported before that date.

**1.5** Homologation shall comprise the confirmation by the Regulatory Authority that the manufacturer has provided the Regulatory Authority with the following specific evidence in respect of the commodity covered by this compulsory specification:

- a) a summary of evidence showing that all relevant tests have been conducted with successful results under appropriate controls in respect of the model or the type of the commodity;
- b) sufficient data to enable a relevant model or type and its components to be identified and related to (a) above;
- c) relevant samples for the conducting of whatever tests and inspections are considered appropriate by the Regulatory Authority, to verify any or all of the evidence provided;
- d) details of the quality management system applied by the manufacturer;
- e) when relevant, documentation to advise subsequent manufacturers of incomplete commodities of their responsibilities; and
- f) agreement by the manufacturing source, to permit conformity of production audits to be carried out by the Regulatory Authority at the relevant manufacturing, assembling and test facilities.

The Regulatory Authority may issue such confirmation, on application, in respect of new models or types, provided that such confirmation may not be used for the purpose of advertising or to imply that all units of the commodity necessarily or consequently comply with all the requirements of this specification.

**1.6** Where an SABS standard, including an international standard, or an ECE regulation adopted by the SABS, is incorporated by reference into this specification, only the technical requirements/specification for the commodity, and the tests to verify the compliance, apply.

## 2 Definitions

For the purposes of this specification, the following definitions apply:

### 2.1

#### **agricultural trailer**

a low speed trailer designated as such by the manufacturer, and intended to be towed by a vehicle that does not exceed 40 km/h

### 2.2

#### **category O:**

##### a) category O<sub>3</sub>

trailers with a maximum weight exceeding 3,5 metric ton but not exceeding 10 metric ton; and

##### b) category O<sub>4</sub>

trailers with a maximum weight exceeding 10 metric ton

### 2.3

#### **manufacturer**

the person who manufactures, produces, assembles, alters, modifies, adapts or converts a new category O vehicle, and "manufacture" has a corresponding meaning

### 2.4

#### **maximum weight**

the maximum mass of a vehicle and its load as specified by the manufacturer

### 2.5

#### **model**

the manufacturer's description for a series of vehicle designs that do not differ in respect of axle configuration and does not exceed the trailer's gross axle mass load.

The Regulatory Authority reserves the right to decide on which variations or combinations of variation constitute a new model, and may also take cognisance to the classification system applied in the country of origin of the design

### 2.6

#### **public road**

a road, street or thoroughfare, including the verges, or any other place, whether a thoroughfare or not, to which the public have the right of access and that they commonly use

### 2.7

#### **regulatory authority**

an organization appointed by the Minister of the Department of Trade and Industry to implement this compulsory specification on behalf of the South African Government

### 2.8

#### **semi-trailer bus**

a category O semi-trailer, that is intended to be drawn by a category N truck-tractor, the combination of which is designed or adapted for the conveyance of a driver and more than eight passengers. (See also 3.3.)

### 3 General requirements

#### 3.1 Requirements for lights, lighting equipment and rear warning signs

##### 3.1.1 Lights

Lights fitted to a trailer shall comply with the relevant requirements as given in the following:

SABS ECE R3, *Uniform provisions concerning the approval of retro-reflecting devices for power driven vehicles and their trailers;*

SABS ECE R4, *Uniform provisions for the approval of devices for the illumination of rear registration plates of motor vehicles (except motorcycles) and their trailers;*

SABS ECE R6, *Uniform provisions concerning the approval of direction indicators for motor vehicles and their trailers;*

SABS ECE R7, *Uniform provisions concerning the approval of front and rear position (side) lamps, stop-lamps and end outline marker lamps for motor vehicles (except motor cycles) and their trailers;*

SABS ECE R23, *Uniform provisions concerning the approval of reversing lights for power driven vehicles and their trailers;*

SABS ECE R37, *Uniform provisions concerning the approval of filament lamps for use in approved lamp units of power driven vehicles and trailers; and*

SABS ECE R91, *Uniform provisions concerning the approval of side-marker lamps for motor vehicles and trailers.*

##### 3.1.2 Lighting and retro-reflectivity

Lighting and retro-reflective markings shall be fitted to a trailer and shall comply with the relevant requirements given in SABS ECE R48, *Uniform provisions concerning the approval of vehicles with regard to the installation of lighting and light-signalling devices* and SABS ECE R104, *Uniform provisions concerning the approval of retro-reflective markings for heavy and long vehicles and their trailers.*

The requirements for the installation of retro-reflectors may be met by the use and fitting of retro-reflectors that are defined in the relevant regulations of the Road Traffic Act, 1989 (Act 29 of 1989), or the National Road Traffic Act 1996 (Act 93 of 1996) and in addition, the requirements may also be met by the use and fitting of retro-reflectors that are integral portions of any other light lens assembly.

##### 3.1.3 Rear warning sign (chevrons)

A rear warning sign shall be fitted to a trailer and shall comply with the relevant requirements of the Road Traffic Act, 1989 (Act 29 of 1989) or the National Road Traffic Act, 1996 (Act 93 of 1996).

#### 3.2 Requirements for windows and partitions

##### 3.2.1 Glass partitions and windows fitted to any trailer shall be:

- a) of safety glass that complies with the relevant requirements given in SABS 1191, *Safety glass for vehicles – High penetration resistant laminated safety glass for vehicles*, SABS 1192, *Safety glass for vehicles – Laminated safety glass for vehicles* or SABS 1193, *Safety glass for vehicles – Toughened safety glass for vehicles*; or

- b) of plastics safety glazing material that complies with the relevant requirements of SABS 1472, *Plastics safety glazing materials for motor vehicles*.

**3.2.2** For the purpose of this specification, the marking requirements shall be as follows:

- a) the glass shall bear the glass manufacturer's registered trade mark; and
- b) the glass fitted shall comply with an approved national standard, recognized by the Regulatory Authority, that will provide a method of identifying the glass type.

### **3.3 Requirements for brakes and braking equipment**

A vehicle shall be fitted with braking equipment that complies with the relevant requirements given in SABS ECE R13, *Uniform provisions concerning the approval of vehicles of categories M, N and O with regard to braking*.

For the purposes of braking requirements for a semi-trailer bus, the vehicle shall be considered as a category O commercial vehicle.

### **3.4 Pneumatic braking system connections**

A vehicle shall be fitted with a pneumatic braking system that complies with the relevant requirements given in SABS 1477-1, *Pneumatic braking system connections between drawing and drawn vehicles – Part 1: Contact type couplings*, SABS 1477-2, *Pneumatic braking system connections between drawing and drawn vehicles – Part 2: Palm type couplings* and SABS 1477-3, *Pneumatic braking system connections between drawing and drawn vehicles – Part 3: The arrangement of connections on vehicle, using contact type or palm type couplings*.

### **3.5 Requirements for electrical connectors**

Electrical connectors that are fitted for the purpose of towing, shall comply with:

- a) in the case of 12 V systems:
- 1) SABS 1327, *Electrical connectors for towing and towed vehicles (7-pole connectors)*, or
  - 2) SABS ISO 11446, *Passenger cars and light commercial vehicles with 12 V systems – 13-pole connectors between towing vehicles and trailers – Dimensions and contact allocation*; and
- b) in the case of 24 V systems:
- 1) SABS 1327, *Electrical connectors for towing and towed vehicles (7-pole connectors)*; or
  - 2) SABS ISO 12098, *Commercial vehicles with 24 V systems – 15-pole connectors between towing vehicles and trailers – Dimensions and contact allocation*.

### **3.6 Requirements for couplings on semi-trailers**

#### **3.6.1 Kingpin and mounting plate**

A semi-trailer shall be equipped with a fifth-wheel kingpin that is securely fitted to a mounting plate on the semi-trailer.

The kingpin shall be of type 50 or type 90. The combination of the kingpin and mounting plate shall be capable of supporting the appropriate mass-load. The dimensions of a type 50 and type 90 kingpin shall comply with those given in figure 1.

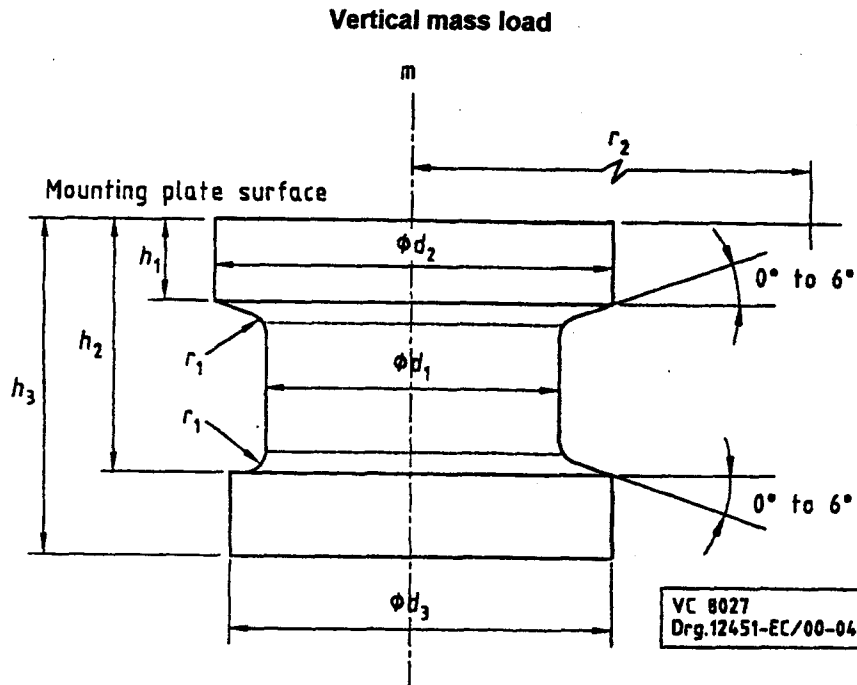

Parameter	Dimensions of kingpin mm	
	Type 50	Type 90
	$\phi d_1$	50,8 ± 0,1
$\phi d_2$	73,0 ± 0,1	114,0 ± 0,1
$\phi d_3$	71,5 ± 0,4	111,0 ± 0,4
$h_1$	35 + 0 - 3,0	21 + 0 - 3,0
$h_2$	70 + 1,5 - 0	59 + 1,5 - 0
$h_3$	84 + 0 - 1,5	74 + 0 - 2,0
Radius $r_1$	3,0 + 0,5 - 0	3,0 + 0,5 - 0
Radius $r_2$	At least 485	At least 485
	Vertical mass load tons	Vertical mass load tons
$m$	Not more than 20	Over 20

**Figure 1 — Kingpin details**

The mounting plate surface shall be flat within 1,5 mm total indicator reading (TIR) over a radius of at least 485 mm from the axis of the kingpin. The geometry of the kingpin/mounting plate combination shall be such that when the relevant gauge, shown in figure 2, is placed in contact with the mounting plate surface across any transverse diameter, the kingpin is able to pass through the gauge with the gauge still in contact with the surface.

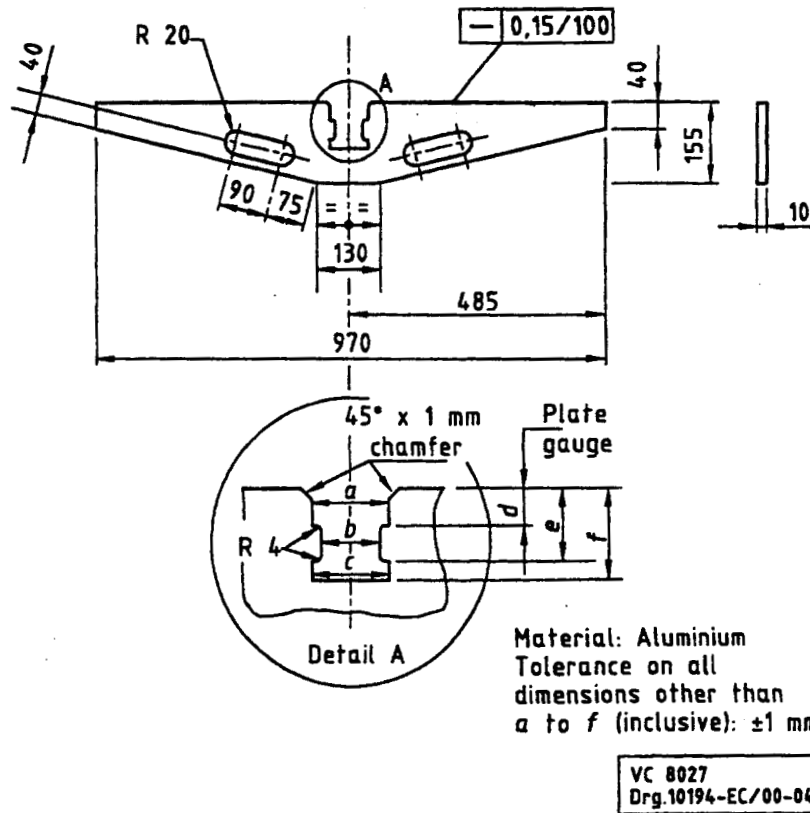

1	2	3
Parameter	Dimensions of kingpin mm	
	Type 50	Type 90
a	74,5	116,3
b	53,4	93,5
c	74,7	115,7
d	37,6	23,0
e	68,0	57,0
f	85,4	75,2

NOTE Tolerance on all above dimensions ± 0,05 mm.

Figure 2 — Details of the kingpin/mounting plate gauge

The axis of a kingpin shall, at any point on the mounting plate surface within a radius of at least 485 mm from the axis of the kingpin, be at an angle of  $90^\circ \pm 1^\circ$  to the mounting plate surface.

3.6.2 Mechanical properties of kingpin

A kingpin shall have mechanical properties equal to or better than those given in table 1.

**Table 1 — Mechanical properties of kingpin**

1	2
Mechanical property	Value
Tensile strength, MPa	850 – 1 000
Yield stress, MPa, min.	680
Elongation, %, min.	13
Izod impact value, J, min.	54
Hardness, HB	250 – 300

### 3.7 Requirements for rear underrun protection devices

A rear underrun protection device shall be fitted to a trailer and shall comply with the relevant requirements given in SABS 1055, *Motor vehicle safety: Rear underrun protection devices*.

### 3.8 Requirements for warning triangles

In the case of a vehicle supplied with a warning triangle as part of the vehicle equipment, such a warning triangle shall comply with the requirements of SABS 1329-1, *Retro-reflective and fluorescent warning signs for road vehicles – Part 1: Triangles*.

## 4 Requirements concerning metrological data

### 4.1 Trailer dimensions

The dimensions of a trailer shall comply with the requirements of the relevant regulations of the Road Traffic Act, 1989 (Act 29 of 1989) or the National Road Traffic Act 1996 (Act 93 of 1996).

### 4.2 Information plates

#### 4.2.1 Data plate

A trailer shall have, permanently affixed to it in a conspicuous position, and visible from the left-hand side of the trailer, a data plate or plates. The following information shall be legibly and permanently imprinted or stamped on the data plate(s):

- a) the gross vehicle mass, in kilograms, prefixed by the letters "GVM/BVM";
- b) the gross axle mass-load or gross axle unit mass-load of each axle or axle unit, in kilograms, prefixed by the letters "GA/BA" or "GAU/BAE", as applicable;
- c) if the trailer is a semi-trailer, the gross kingpin mass-load in kilograms, prefixed by the letters "GKM/BSM";
- d) the manufacturer's design intent, denoted by the wording "For public road operation"; and
- e) the month and the year of manufacture, denoted by four numeric digits, two for the month, followed by two for the year (for example, July 1987 would be denoted by 0787).



#### 4.2.2 Vehicle Identification Number (VIN)

A trailer shall have a vehicle identification number that complies with the relevant requirements given in SABS ISO 3779, *Road vehicles – Vehicle identification number (VIN) – Content and structure*, and SABS ISO 4030, *Road vehicles – Vehicle identification number (VIN) – Location and attachment*.

However, the requirements for the VIN, as given in clause 5 of the said SABS ISO 4030, shall, for the purpose of this compulsory specification, be taken to read as follows:

### 5 VIN attachment

5.1 The VIN shall be marked directly on any integral part of the vehicle; it may be either on the frame, or, for integral frame body units, on a part of the body not easily removed or replaced.

5.2 The VIN shall also be marked on the data plate.

5.3 Deleted.

5.4 The height of the roman letters and the arabic numerals of the VIN shall be as follows:

- at least 7 mm if marked in accordance with 5.1 (frame, body, etc.) on motor vehicles and trailers; and
- at least 3 mm if marked in accordance with 5.2 (data plates).

#### 4.3 Provision for registration

Suitable spaces shall be provided on the data plate(s) referred to in 4.2.1:

- a) T.....kg (for tare);
- b) V.....kg (for the permissible maximum trailer mass); and
- c) A.....kg or AU/AE...kg, as applicable (for the permissible axle mass-load or permissible axle unit mass-load of each axle or axle unit).

The responsibility for the marking of this information on the data plate(s) shall rest with the trailer manufacturer.

#### 4.4 Axle brake data plates

Each axle on a trailer shall be provided with information applicable to the brake design, the particulars of which shall be permanently and legibly imprinted or stamped either on a data plate permanently affixed in a conspicuous position adjacent to the axle or on the plates as required by SABS ECE R13, given as follows:

- a) the axle make and serial number;
- b) the brake chamber size and the brake lever length;
- c) the maximum tyre size; and
- d) brake lining material type and grade.

#### **4.5 Measuring units**

All gauges, indicators or instruments that are fitted to a trailer and that are calibrated in physical units shall be calibrated in units as prescribed by the current applicable regulations promulgated under the Measuring Units and National Measuring Standards Act, 1973 (Act 76 of 1973).

### **5 Requirements for the control of environmental interference**

#### **5.1 Suppression of radio and television interference**

All components, accessories or equipment fitted to a trailer and that generate and radiate electromagnetic energy, shall comply with the current applicable regulations relating to interference with communications, promulgated under the Telecommunications Act, 1996 (Act 103 of 1996).

#### **5.2 Suppression of atmospheric pollution**

All engines, accessories or equipment fitted to a trailer and that generate smoke emissions, shall comply with the current regulations promulgated under the Atmospheric Pollution Prevention Act, 1965 (Act 45 of 1965).

### **6 Requirements for trailer equipment, components and systems**

#### **6.1 Tyres**

Tyres for trailers shall comply with the relevant requirements of the compulsory specification for pneumatic tyres for commercial vehicles and their trailers.

#### **6.2 Wheel flaps**

All trailers of gross mass exceeding 3,5 t shall be fitted with wheel flaps that comply with the relevant requirements given in SABS 1496, *Wheel flaps fitted to motor vehicles*.

Provided that:

chassis-only trailers that are being driven to a place to have body work fitted or to a dealer of such vehicles are excluded from the requirement for the fitment of wheel flaps.

#### **6.3 Axle or axle unit suspension**

A semi-trailer shall be fitted with axle suspension that complies with the relevant regulations of the National Road Traffic Act, 1996 (Act 93 of 1996).

### **7 Compliance requirements**

Proof of compliance shall be provided by the manufacturer, importer or builder (MIB) to the inspectorate authority in respect of each motor vehicle model covered by the scope of this specification.

Such proof of compliance shall be made available in the English language, so that the inspectorate authority can satisfy itself that compliance has been achieved prior to any such vehicle being registered in the Republic of South Africa.

Failure to provide such proof of compliance within five working days of submitting an application for homologation to the inspectorate authority, shall constitute reasonable grounds to suspect that the motor vehicle model does not comply with the requirements of this specification.

## **8 Equivalent requirements**

The requirements of any of the SABS standards in the appropriate parts of clause 3 of this specification shall be deemed to have been met if compliance with the listed EEC or ECE requirements given in table 2, are achieved.

**SCHEDULE — Operative dates**

1	2	3	4	5
Subsection	Item	Operative date	Exclusions	Exclusion expiry date
	All subclauses/items not referred to below	1 September 1992 and 1 January 2001	Nil	
3.1.1	Lights to SABS ECE R3 SABS ECE R4 SABS ECE R6 SABS ECE R7 SABS ECE R23 SABS ECE R37 SABS ECE R91	1 January 2001	Nil	
3.1.2	Lighting to SABS ECE R48 Markings to SABS ECE R104	1 January 2002 1 January 2002	Nil	
3.3	Braking to SABS ECE R13	1 January 2002	Nil	
3.4	Pneumatic connections to SABS 1477	1 January 2002	Nil	
6.3	Axle suspension to National Road Traffic Act	1 January 2002	Nil	

NOTE 1 Vehicles that comply with any SABS, ECE or EEC standard that supersedes the above-mentioned standards, shall be deemed to comply with the relevant requirements of this compulsory specification.

NOTE 2 The exclusions listed in this schedule should be read in conjunction with other exclusions that are in the body of the specification, or in any applicable SABS standard.

**Table 2 — Equivalent standards that shall be deemed to comply with SABS standards**

1	2	3	4	5	6	7	8	9
Equivalent standards								
Subsection	Item	SABS No.	Dated	EEC	Inclusive	ECE	Others	Remarks
3.1.1	Lights			76/757 76/760 76/759 76/758 77/539 76/761 76/758	97/29 97/31 89/277 97/30 97/32 89/517 97/30	R3 R4 R6 R7 R23 R37 R91		
3.1.2	Installation of lights	1046	1990	76/756	89/278	R48		
3.2	Safety glazing	1191 1192 1193	1978 1978 1978	92/22 92/22 92/22		R43 R43 R43		
3.3	Brakes and braking	1506	1990	71/320	85/647	R13.05		
3.6	Rear underrun	1055	1983	70/221	81/333	R58		
6.3	Axle suspension						NRTA	
NOTE Vehicles that comply with any SABS or equivalent standards that supersedes the above-mentioned standards, may be deemed to comply with such a standard.								